

Non-excitation BRAKES

SINFONIA's clutches and brakes used in various equipment including industrial equipment, information equipment and recreation facilities play an important part in automation or motion control systems.



For safe and reliable operation, it is essential to read the user's manual carefully before using this equipment.

We have a new slogan in Japan; "ECOing" a combination of "eco" and "ing". This is to promote eco-friendly technological development and manufacturing. Our ecological activities are of course not limited to Japan and practiced in many countries around the world.

SINFONIA TECHNOLOGY CO., LTD. continually upgrades and improves its products. Actual features and specifications may therefore differ slightly from those described in this catalog.

Formerly SHINKO ELECTRIC CO., LTD.

SINFONIA SINFONIA TECHNOLOGY CO., LTD.

Shiba NBF Tower, 1-30, Shiba-daimon 1-chome, Minato-ku, Tokyo, 105-8564, Japan
TEL +81-3-5473-1826 FAX +81-3-5473-1845

SINFONIA TECHNOLOGY (SINGAPORE) PTE. LTD.

96 Robinson Road, #13-02 SIF Building, Singapore 068899
TEL +65-6223-6122 FAX +65-6225-2729

PT. SINFONIA TECHNOLOGY INDONESIA

Graha Paramita 8th Floor Suite E Jl. Denpasar Raya Block D2 KAV. 8 Kuningan, Jakarta 12940, Indonesia
TEL 021-252-3606 (hunting) FAX 021-252-3608

SINFONIA TECHNOLOGY (THAILAND) CO., LTD.

12th Floor Room 1205, 319 Chamchuri Square Building, Phayathai Road, Pathumwan Bangkok 10330, Thailand
TEL +66-2160-5068 FAX +66-2160-5069

SINFONIA TECHNOLOGY (SHANGHAI) CO., LTD.

Room3006, Building B Far East International Plaza, No 317, Xian Xia Road, Changning District, Shanghai, China
Zip Code:200051
TEL +86-21-6275-0606 FAX +86-21-3209-8975

CODE <http://www.sinfo-t.jp/eng/>

E77-220

201703B1.55



SINFONIA TECHNOLOGY CO., LTD.
Formerly SHINKO ELECTRIC CO., LTD.

Secure and safe electro-magnetic brakes of non-excitation operating type used in a wide variety applications for holding and braking.

Brakes of the non-excitation operating type (off brake) are used widely in every field for holding and braking, and therefore have become indispensable functional components for securing safety or preventing accidents. SINFONIA manufactures various brakes of the non-excitation operating type to provide customers with optimum products based on their requests. In addition, SINFONIA can satisfy customer requests by designing brakes for specific applications.

List of electro-magnetic brakes of non-excitation operating type																					
Type	Application			Motion		Features								Range of static friction torque					Examples of use		
	Holding	Emergency stop	Braking	Spring braking	Permanent magnet braking	Slim type	High response	Torque adjustment	Manual release	Silent operation	Non-backlash	Non-contact	Automatic gapping	0.1	1	10	100	1000 (Nm)			
SBR	●	●		●		●	●		●	●					0.3~45					<ul style="list-style-type: none"> • Holding operation for servo motors and stepping motors. • Holding operation for robot arms. • Holding operation for screw axes. 	4 5
SBM	●	●	●	●			●	●	●	●					2~37					<ul style="list-style-type: none"> • Geared motors • Brake motors • Shutters • Escalators • Elevators • Golf carts • Multi-story parking garages • Automatic travel cart and transfer carts • Stage settings • Take up drums and reels 	6
SBS	●	●	●	●					●						15~1500					<ul style="list-style-type: none"> • Brake motors • Cranes and hoists • Winches • Automatic warehouse systems • Take up drums • Lifters (lifting gears) • Various transferring units 	7
BBS	●	●	●	●								●			0.5~10					<ul style="list-style-type: none"> • Compact control motors • Compact induction motors 	8
ERS	●	●	●		●		●				●	●	●		0.45~350					<ul style="list-style-type: none"> • Stepping motors • Brake motors • Industrial robots • Transferring units • Medical equipment • Welfare equipment • General industrial equipment 	9 10

The mark "●" indicates the main features of each series. As for details, please refer to the corresponding pages of each series.

Safety precautions

Be sure to read this instruction before operation.

When using our products, please pay sufficient attention to safety and perform the operation correctly by thoroughly reading and understanding our catalogs and technical information beforehand.

Although we make every effort to secure quality control of our products, please carefully consider safety measures for machine operation in the case of failure of the machine.



DANGER
If you fail to follow the instructions, it may lead to death or serious injury of operators.



CAUTION
If you fail to follow the instructions, it may lead to injury of operators and physical loss or damage.

DANGER



Never use the products in an atmosphere with risk of ignition and explosion.

Sparks may be generated by slipping when braking. Never use the products in an atmosphere containing oil and combustible gases, etc., as there is a risk of ignition and explosion. In addition, be sure to cover the main body tightly when using in an environment with combustible materials such as cloth.



Bolts must be selected and used based on the specified strength taking complete measures to prevent loosening.

Bolts in an inappropriate tightening state may be destroyed by shear stress to result in a very dangerous state. Be sure to select and use the specified bolt materials by applying the defined torque, and then take measures to prevent them from loosening using an adhesive agent or spring washers.



Never repair, disassemble, or modify the products.

Due to the nature of our brake products, never request a third party other than SINFONIA or an agent designated by SINFONIA to repair, disassemble, or modify our brake products. In addition, should an accident or damage occur resulting from a repair defect by a third party, SINFONIA shall not be held responsible.



The SBR type cannot be used for braking.

The SBR type is a brake specially designed for holding and emergency stops. If it is constantly used for braking, the primary function will be lost after a short period of time resulting in release failure. If it is used as it is, the brake will burn out losing its braking force, which may cause an accident such as the machine losing control.

(Note: For braking, please select one among our non-excitation operating brakes, SBM, SBS, and ERS.)

CAUTION



Check the peripheral environment before using the products.

Never use the products in a place exposed to water drops, oil drops, or dust, a place with vibration or shock, or a place of high temperature and humidity, as it may result in damage or malfunction of the products.



Brakes of the non-excitation operating type are released when electricity flows to the coil.

Make sure the application and purposes of use are appropriate before selection and design.

SBR

High friction material type

Spring closing brakes
For holding and emergency stops

This type has a higher performance by loading new friction materials.

Features

- (1) Operates immediately at power off Secured during a power failure
- (2) No need to adjust gap when mounted
- (3) Demonstrates 100% initial torque
- (4) Applies own high performance friction material
- (5) Free mounting orientation
- (6) Thin type realized significant thinning

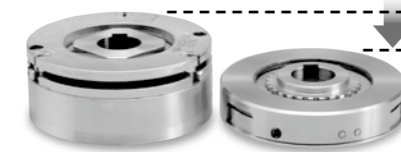

SBR

Structural drawing

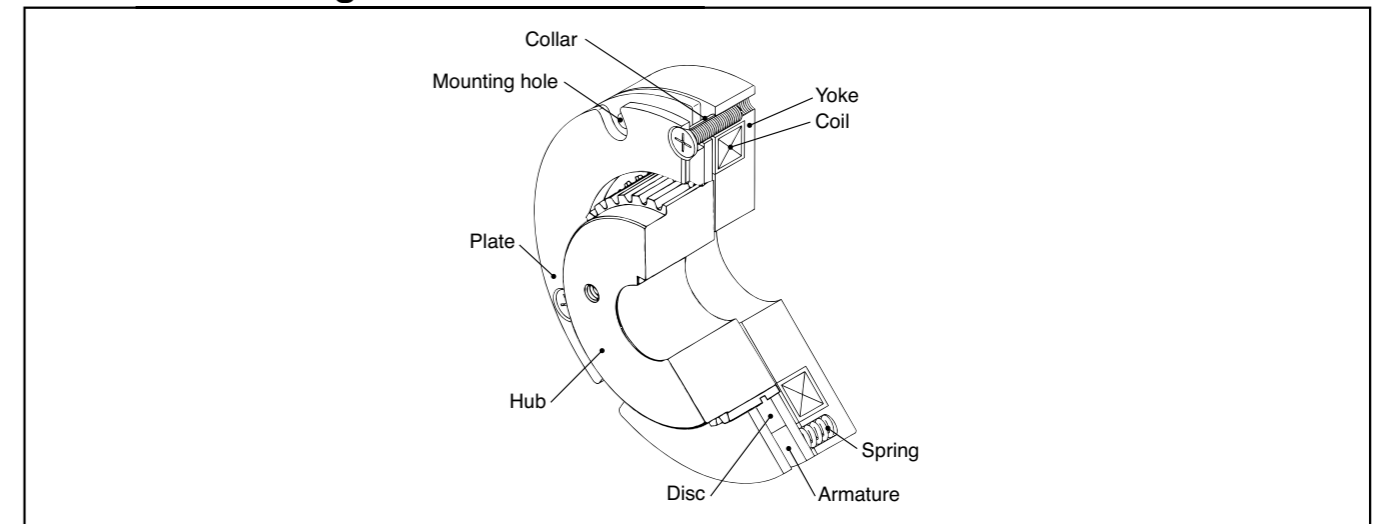

Response Characteristics

Type / SBR-	32-0003EZ	42-0015EZ	62-0030EZ	82-0100EZ	112-0160EZ	152-0450EZ
Armature pull-in time t_a (ms)	35	50	60	100	110	120
Armature release time t_{ar} (ms)	20	20	20	30	30	50

Allowable workload / Max speed / Inertia J

Type / SBR-	Allowable workload(J)		Max speed (r/min)	J (kgm ²)	Number of stops		Heat resistance class	Initial armature pull-in voltage (at20°C)	Initial armature release voltage (at20°C)	Mounting direction
	Per single time	Total workload			Normal holding (0r/min)	Emergency braking				
32-0003EZ	27	1.0×10^4	6000	3.7×10^{-7}	2,000,000	200	H	Less than DC15V	More than DC1V	Free
42-0015EZ	100	4.5×10^4		2.4×10^{-6}						
62-0030EZ	200	1.0×10^5		8.6×10^{-6}						
82-0100EZ	500	5.0×10^5	3.7×10^{-5}							
112-0160EZ	1000	1.0×10^6		1.6×10^{-4}						
152-0450EZ	1500	1.0×10^6	3600	4.5×10^{-4}						

SBR-32-0003EZ

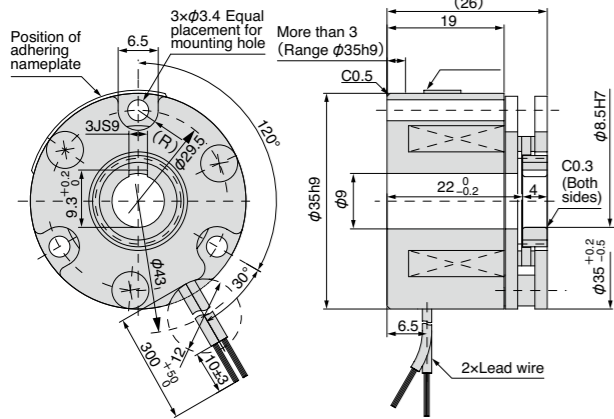

Static friction torque	Nm	0.35
Rated voltage	DC-V	24
Power consumption	W(at75°C)	6.3
Weight	kg	0.14

SBR-42-0015EZ

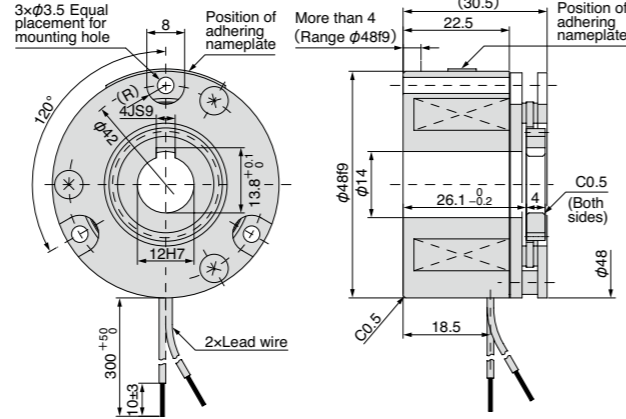

Static friction torque	Nm	1.5
Rated voltage	DC-V	24
Power consumption	W(at75°C)	7.2
Weight	kg	0.3

SBR-62-0030EZ

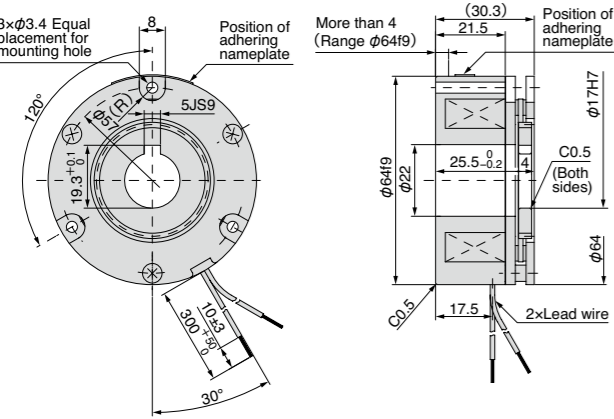

Static friction torque	Nm	3
Rated voltage	DC-V	24
Power consumption	W(at75°C)	8.5
Weight	kg	0.5

SBR-82-0100EZ

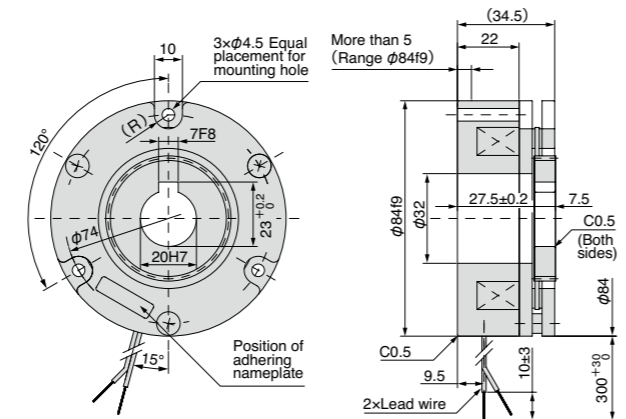

Static friction torque	Nm	10
Rated voltage	DC-V	24
Power consumption	W(at75°C)	17.7
Weight	kg	1

SBR-112-0160EZ

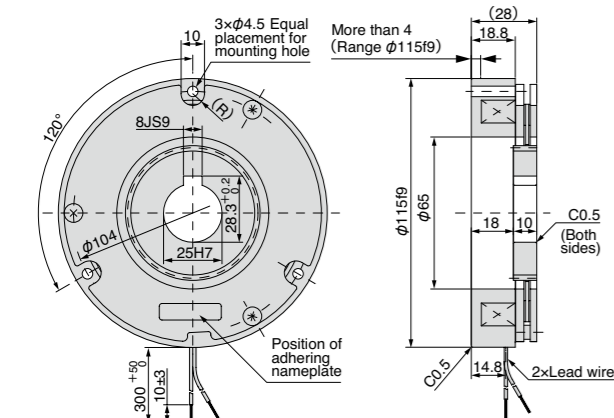

Static friction torque	Nm	16
Rated voltage	DC-V	24
Power consumption	W(at75°C)	23
Weight	kg	1.5

SBR-152-0450EZ

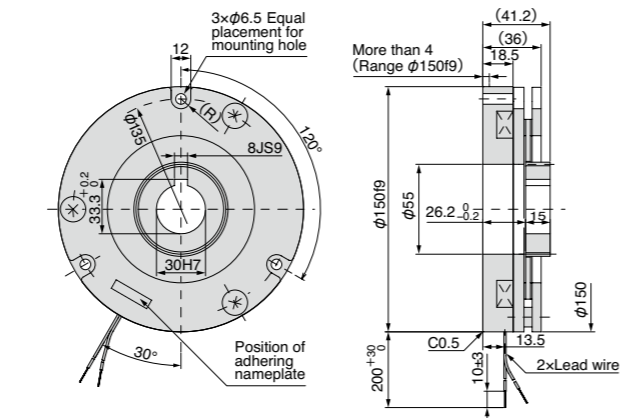

Static friction torque	Nm	45
Rated voltage	DC-V	24
Power consumption	W(at75°C)	24
Weight	kg	3.6

This type can be mounted easily and excels under severe operations.

Features

- (1) This type is designed to excel against wear resistance and high heat diffusion. It is easy to mount on general purpose motors.
- (2) This type will maintain a steady and high response braking performance when performing frequent braking operations.

* Upon request we can provide a compact module type of the power source device DMS-90RS for SBM-115-160 types.



Structural drawing

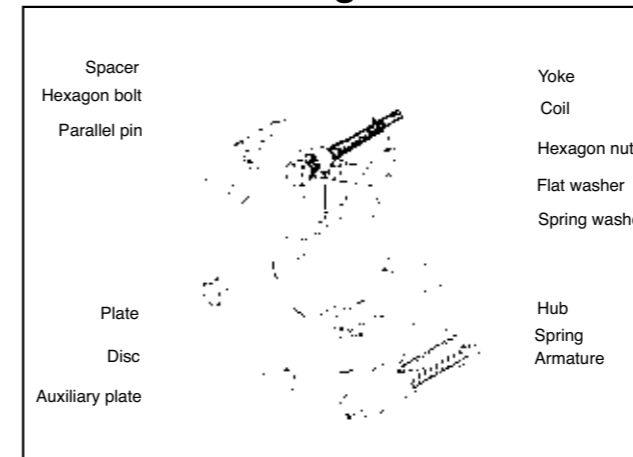

Outline drawing

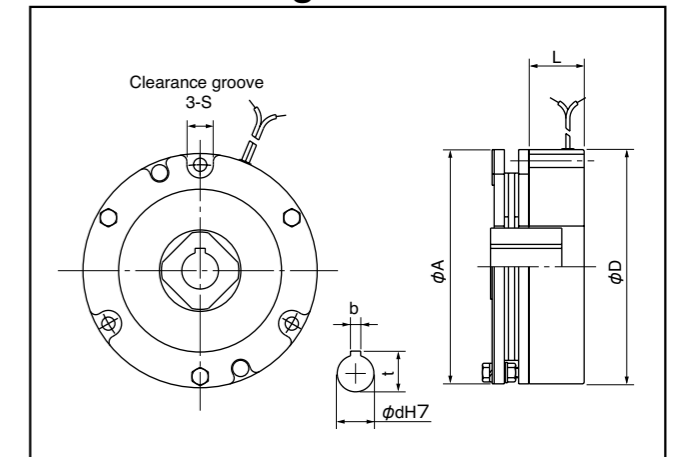

Specifications and properties

Type / SBM-	90-02	90-04	115-07	140-15	160-22	160-37
Static friction torque Nm	2	4	7.5	15	22	37
Rated voltage	AC200/220V	AC200/220V	DC90V	DC90V	DC90V	DC90V
Power consumption W(at75°C)	16	16	20	22	26	26
Weight kg	1.5	1.5	2.6	3.9	6.0	6.0

Dimension list

Type / SBM-	90-02	90-04	115-07	140-15	160-22	160-37
A	90	90	115	140	160	160
D	90	90	115	140	160	160
L	47	47	50	50	59	59
S	11	11	13	13	16	16
d	12	14	18	22	22	28
b	—	—	5	7	7	7
t	—	—	20	25	25	31

No key grooves for the 90 type.

SBS

Standard type

Spring closing brakes
For braking

Highly versatile and easy-to-use.

Features

This type is a dry and multiple-disc electromagnetic brake for non-excitation operation. Multiple discs can produce a high torque, even though the outer dimension is small, and can be adopted for braking and emergency stops in various fields. Changing the number of discs with the same outer dimension can control static friction torque. Upon request we can provide many types of power sources and standard control devices.

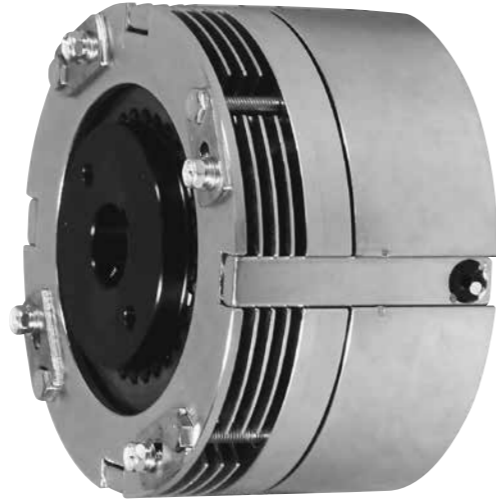

Structural drawing

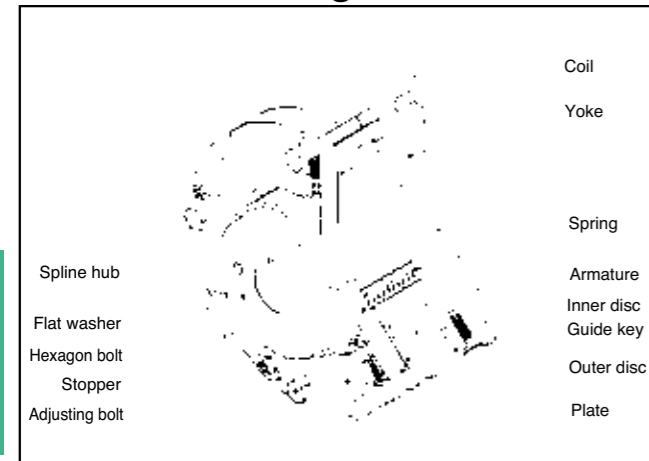

Outline drawing

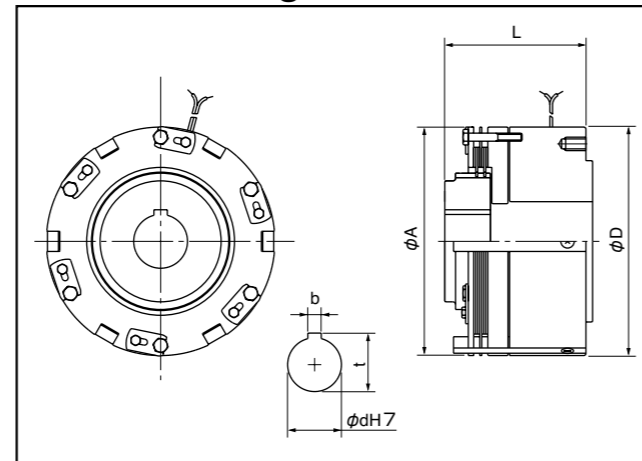

Specifications and properties

Type / SBS-	120-4D	120-8D	140-4D	140-8D	170-4D	170-8D	230-4D	230-8D	300-4D	300-8D
Static friction torque Nm	15	30	30	60	60	120	260	500	800	1500
Rated voltage DC-V	24	24	24	24	24	24	24	24	24	24
Power consumption W(at75°C)	23	23	28	28	38	38	62	62	82	82
Weight kg	5	5	8	8	15	15	30	30	70	70

Dimension list

Type / SBS-	120-4D	120-8D	140-4D	140-8D	170-4D	170-8D	230-4D	230-8D	300-4D	300-8D
A	120	120	140	140	170	170	230	230	300	300
D	120	120	140	140	170	170	230	230	300	300
L	80	80	95	95	110	110	145	145	200	200
d	20	20	25	25	40	40	55	55	75	75
b	5	5	7	7	10	10	15	15	20	20
t	22	22	28	28	43.5	43.5	60	60	81	81

BBS

Compact type

Spring closing brakes
For holding and emergency stops

This type is a compact type categorized for the smallest class among non-excitation operating types.

Features

- (1) This type has a unique center spring structure where the dimensions of both the axial direction and the diameter are very small, and is an extremely compact type categorized for the smallest class among non-excitation operating types, so it is easy to perform mounting work at even in narrow spaces.
- (2) Thanks to strong materials and coil springs, this type has a long life and will maintain a steady performance at a high response for a long time.
- (3) Thanks to its non-contact mechanism, there is no trouble such as generation of dragging torque or rubbing noise.
- (4) Thanks to carefully selected parts and a simple structure, the cost of machine design can be reduced.



Structural drawing

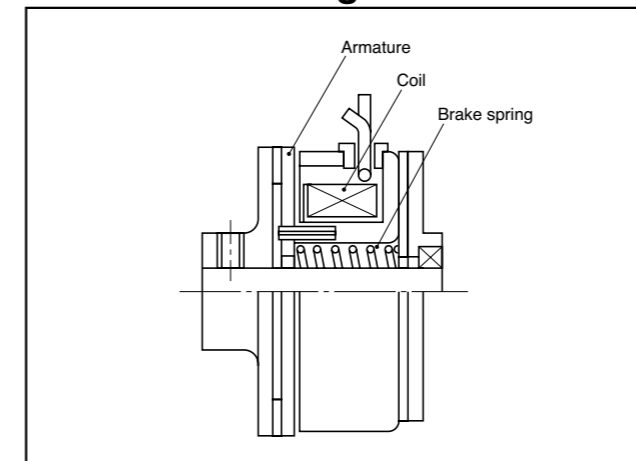

Outline drawing

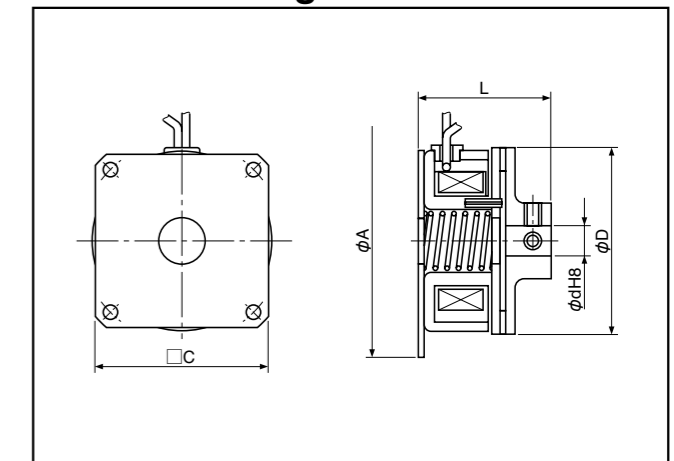

Specifications and properties

Type / BBS-	4-05	4-1	4-3	4.9	7
Static friction torque Nm	0.05	0.1	0.3	0.5	1
Rated voltage DC-V	45	45	45	45	45
Power consumption W(at75°C)	3.6	3.6	3.6	8	9
Weight kg	0.15	0.15	0.15	0.5	0.5

Dimension list

Type / BBS-	4-05	4-1	4-3	4.9	7
A	52	52	52	65	88.87
D	39	39	39	49	70
L	29	29	29	37	40
d	6	6	6	10	15

This series is order made, so please inquire separately.

ERS-A

Standard type

Permanent magnet closing brakes
For braking and emergency stops

Fast response is realized by power of the permanent magnet.

Features

- (1) This type of clutch and brake unit realizes outstanding response using powerful permanent magnets.
- (2) Braking torque more than the rated torque is produced by a multiplier effect of both the permanent magnet and coil. It is possible to perform forcible braking operation instantly after releasing.
- (3) Thanks to its high heat diffusion effects, it is possible to perform operation under severe conditions with extreme high frequency.
- (4) Thanks to its unique auto gap adjusting mechanism, there is no need to perform adjustment work after mounting this unit.
- (5) Thanks to its non-contact mechanism, there is no trouble such as generation of dragging torque or rubbing noise.

* Upon request we can provide the standard control device (FMPP-70/24D).



Structural drawing

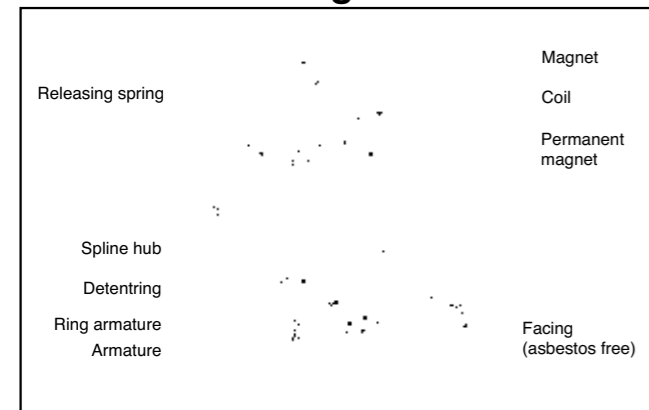

Outline drawing (ERS-260A)

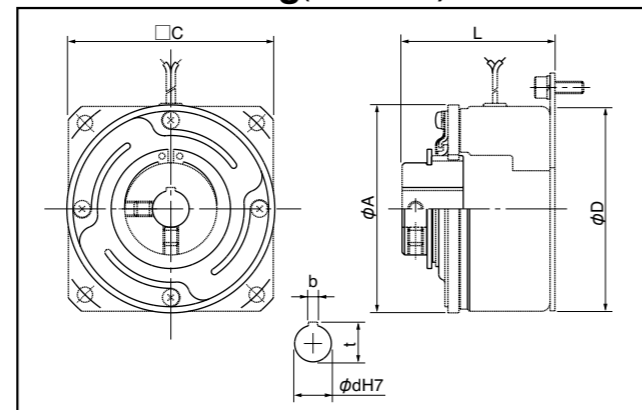

Specifications and properties

Type / ERS-	260A/FMS	400A/FMS	501A/OMS	650A/IMS	825A/IMS	1225A/IMS
Static friction torque Nm	7	20	40	70	120	350
Rated voltage DC-V	24	24	24	24	24	24
Power consumption W(at75°C)	10	8	13	21	23	25
Weight kg	0.70	2.0	4.0	7.2	11	30

Dimension list

Type / ERS-	260A/FMS	400A/FMS	501A/OMS	650A/IMS	825A/IMS	1225A/IMS
A	68	102	133.6	164	218	320.7
C	67	108	127	-	-	-
D	67	103	128	180	215	318
L	50	59.5	75.2	77.4	75.3	92.9
d	12	18	28	28	28	50
b	3	5	7	7	7	12
t	13	20	31	31	31	53.5

As for the dimension of "C" for types 650, 825, and 1225, mounting is not by square flange but by the inner side.

ERS-L

Compact type

Permanent magnet closing brakes
For braking and emergency stops

Slim in axial direction to realize easy mounting work even in narrow spaces.

Features

- (1) This type of clutch and brake unit is compact having the feature of a slim size in the axial direction but realizing high torque while taking advantage of the basic performance of a permanent magnet brake.
- (2) Since the rotating parts and the fixed parts of the unit are in a state of complete non-contact, friction, dragging rotation, noise, and vibration, etc., will not occur during rotation.
- (3) This unit will maintain high accuracy positioning because of its feature of no-backlash.

* Upon request we can provide the standard control device (FMPP-70/24D).



Structural drawing

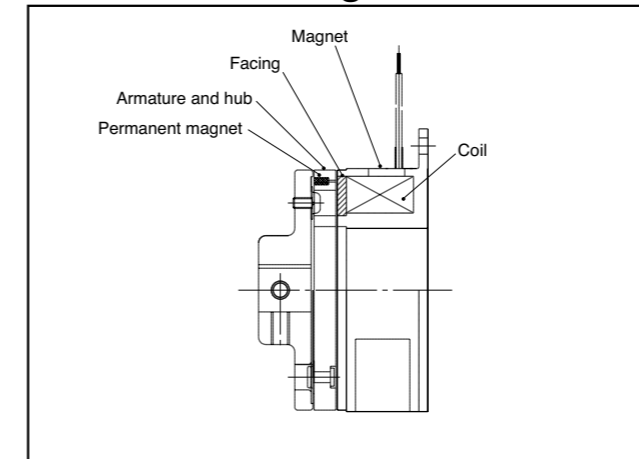

Outline drawing (ERS-260L/FMF)

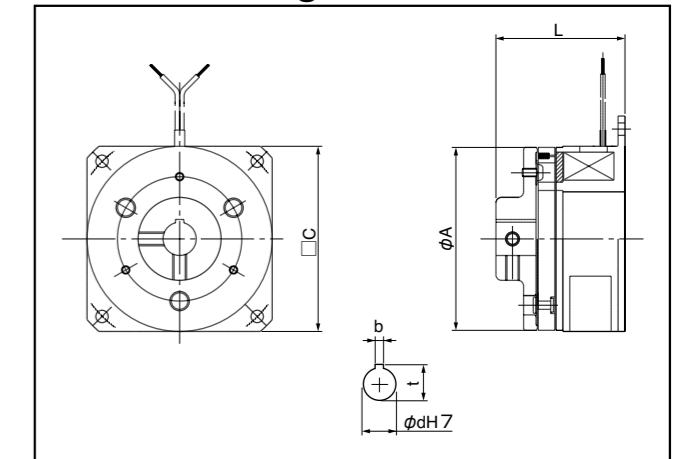

Specifications and properties

Type / ERS-	135L/FMF	175L/FMF	260L/FMF
Static friction torque Nm	0.45	2	8
Rated voltage DC-V	24	24	24
Power consumption W(at75°C)	2	6	10
Weight kg	0.065	0.18	0.51

Dimension list

Type / ERS-	135L/FMF	175L/FMF	260L/FMF
A	26.4	44.3	66.2
C	30	46	67
L	28.8	31	46.7
d	5	10	12
b	-	-	3
t	-	-	13

No key groove for the 175 and 135 types.
The series is order made, so please inquire separately.