

## Matters of inquiry

Please fill in the form below for inquiry

Handling material	a	Name			
	b	Apparent specific gravity	t/m <sup>3</sup>	True density	t/m <sup>3</sup>
	c	granulometry	Max	mm	%
			Max	mm	%
	d	Temperature			
	e	Humidity			
f	Other characteristics				
Process capacity	●Max	t/h	●Average	t/h	
Power source	●Voltage	V	●Frequency	Hz	
Controller (if needed)	●Manual ON·OFF	Manual amplitude control	Manual ON / OFF	Remote amplitude control	
Trough structure	Materials	Buff finishing on SUS			Yes / No
	Dimensions	W :	mm	D :	mm
	Shape	Open · Covered			
	Air proof	Required ( mmAq ) · Unnecessary			
	Linear	Required (Material : ) · Unnecessary			
Motor specification	Covered · Dust proof · Rainproof · Increased safety explosion protection · Pressure resistance explosion protection				
Installation method	Floor mounted · Upstairs · Suspension · On substructure				m
Before and after processes					

 For safe and reliable operation, it is essential to read the user's manual carefully before using this equipment.

We have a new slogan in Japan; "ECOing" a combination of "eco" and "ing". This is to promote eco-friendly technological development and manufacturing. Our ecological activities are of course not limited to Japan and practiced in many countries around the world.

 **SINFONIA TECHNOLOGY CO., LTD.**

Shiba NBF Tower, 1-30, Shibadaimon 1-chome, Minato-ku, Tokyo, 105-8564, Japan  
TEL +81-3-5473-1864 FAX +81-3-5473-1845

**SINFONIA TECHNOLOGY (THAILAND) CO., LTD. Bangkok Sales Office**

12th Floor Room 1205, 319 Chamchuri Square Building, Phayathai Road, Pathumwan Bangkok Bangkok 10330  
TEL +66-2160-5068 FAX +66-2160-5069

**SINFONIA TECHNOLOGY (SINGAPORE) PTE. LTD.**

96 Robinson Road, #13-02 SIF Building, Singapore 068899  
TEL +65-6223-6122 FAX +65-6225-2729

**PT. SINFONIA TECHNOLOGY INDONESIA**

Graha Paramita 8th Floor Suite E Jl. Denpasar Raya Block D2 KAV. 8 Kuningan, Jakarta 12940 Indonesia  
TEL +62-21-252-3606 FAX +62-21-252-3608

CODE

E94-003

Content of this catalogue may change due to product improvement without notice.

URL <http://www.sinfo-t.jp/eng>

Printed in Japan 2015 05B II ©

# Vibrating Conveyors

 **SINFONIA**  
SINFONIA TECHNOLOGY CO., LTD.

# Vibrating Conveyors

**Multiple processing during transit. Smooth, streamlined efficiency.**

The sophisticated demands of the modern age require upgraded processing of particulate materials. Materials are getting finer, new substances are appearing, processing is increasingly computer-controlled, and consumers' needs are more diversified. For advanced processing, more and more attention is now being focused on vibrating conveyors, which are ideally suited for transporting particulate materials

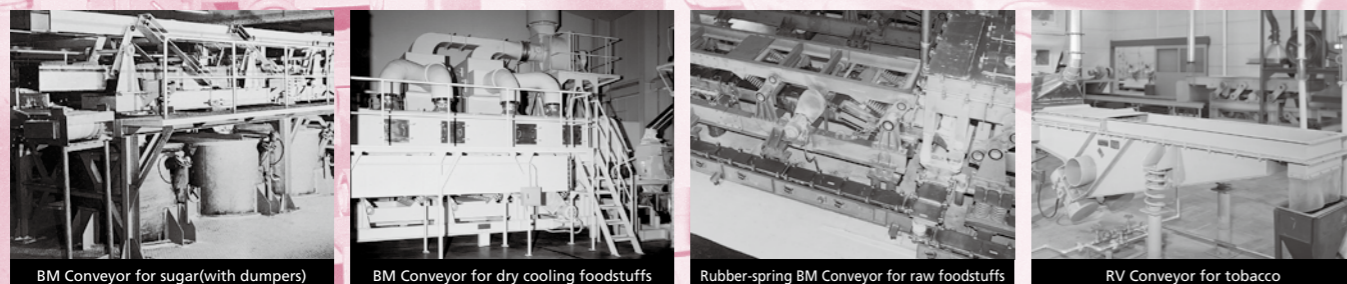

**Designed to meet all needs, whatever the process, material or installation environment are.**

## Features

### 1 Simple construction

The trough itself stays in place and transmits vibration by means of the to-and-fro motion to transport the material. Conveyors are therefore very simple in construction, and are easily installed, even in limited space.

### 2 Accommodates all types of materials

The steel trough can accommodate the conveyance of hot materials as well as cooling operations. All types of materials can be transported, with no limitations posed by particle size, corrosiveness, relative hardness, stickiness, etc.

### 3 Capable to dry, cool, and etc. simultaneously

Processing such as drying, cooling, sorting, draining etc. can easily be carried out at same time, making the conveyance process an incredibly efficient means of transport.

### 4 Reduces costs

Selecting the appropriate vibration frequency for the process in hand can lead to large savings in electricity consumption.

### 5 Maintains clean environment

The equipment can be sealed through the simple attachment of an anti-dust cover, eliminating the spread of even the finest particles and maintaining a clean and comfortable working environment.

### 6 Smooth starts and stops

The drive systems of the MVCB and BM Conveyors have unique rubber springs and the RV Conveyor absorbs the shock of stops with an electrical system, for tremendously smooth operations.

### 7 Minimum downtime

Very few parts rotate, or are subject to friction or wear, or require lubrication, thus eliminating breakdowns and making servicing and maintenance very straightforward.

### 8 Standard steel plate trough

A stainless steel trough or special lining can be used for materials with particular requirements.

## Comparison of vibrating and other conveyors

(Comparing suitability for selected materials ●=suitable, X=unsuitable)

Material	Apparent specific gravity(T/m <sup>3</sup> )	Screw Conveyor	Bucket Conveyor	Belt Conveyor	Vibrating Conveyor
Wet ash	0.72~0.88	X	●	●	●
Dry ash	0.56~0.6	●	●	X	●
Cement	1.36~1.6	●	●	●	●
Chemicals	Abrasive	X	●	●	●
	Corrosive	X	●	●	●
	Sticky	X	X	X	X
Clay	0.56~0.88	●	X	●	X
Coal	0.8	●	●	●	●
Coke	0.64	X	●	●	●
Coke ash	0.48	X	●	●	●
Aluminum scrap		X	X	●	●
Casting sand	1.5~1.6	X	X	●	●
Cereals	0.4~0.96	●	X	●	●
Heavy ores		X	●	●	●
Light ores		●	X	●	●
Metal powder		●	●	●	●
Rocks/stones		X	●	●	●
Salt	0.72~1.28	●	X	●	●
Sand/gravel		X	●	●	●
Sawdust	0.24~0.32	●	X	●	●
Soda ash	0.40~1.05	●	X	●	●
Soybeans	0.72	●	X	●	●
Soybean meal	0.64	●	X	X	●
Starch	0.40~0.64	●	X	●	●
Sugar	0.88	●	X	●	●
Sulphur	0.88~1.0	●	X	●	●
Compound fertilizer	0.5~1.3	X	X	●	●
Perphosphoric acid	1.3	X	X	●	●
Hot materials		X	●	X	●
Large-sized waste		X	X	●	●
Kitchen waste		X	X	●	●

Note: Data for vibrating conveyor based on SINFONIA TECHNOLOGY's 60 years of experience in this field.

## Table of models

Type	Models	Features & applications	Drive method	Vibration-neutralizing effect*1	Vibration magnitude (mm)	Vibration frequency (Hz/s)	Max. trough length*2 (m)	Explosion-proof construction*3	Installation method	
BM Conveyors	BM	Fully balanced type causing no vibration pollution; handles all materials from fine to lumpy.	3-phase induction motor, eccentric shaft action, spring resonators.	5 (1)	10~20	6.7~10.8	120	○△	Base mounted	P.3
Balanced Conveyors	MVCB	Low profile type with minimal overall height. Ideal for teaming up with other equipment, high level installation.		15~20	10~20	6.7~10.8	30	△	Base mounted	P.5
MV Conveyors	MVC	Simple, low cost version. Suited to long distance, narrow bed conveyance. Accommodates drying, cooling etc.	3-phase induction motor, eccentric shaft action, spring resonators (direct impact)	100 (basis)	10~20	6.7~10.8	80	○	Base mounted	P.7
RV Conveyors	RVF	Forced vibration type that can move sticky materials smoothly. Rate of flow easily adjustable.	Forced vibration generated by rotary vibrator (vibration motor)	10~15	2~4	24.2~29.2	6	○	Base mounted; suspended	P.9
	RVF-φ	Tubular trough for fully sealed conveyance. Ideal for airtight conveyance, or for dust-creating materials.			4~6	15.8~19.2				—
Spiral Elevators	RVES	Vertical lifting, spiral trough type. Space saving and can accommodate drying, cooling, etc.	Forced vibration generated by rotary vibrator (vibration motor)	15~20	2~4	24.2~29.2	16 (head)	○△	Base mounted	P.12
					4~6	15.8~19.2				
					5~10	12~14.2				
					20~25	8.2~9.8				
Electromagnetic Vibrating Conveyors	MDC	High frequency vibration type, which used electromagnet. Suitable for food, chemical pharmaceutical and chemical industry.	Resonant vibration type with electromagnetic leaf spring.	5~10	4~6	20~25	6	—	Base mounted	P.14
Slide Conveyors	HDC	Lifting materials with horizontal vibration. Suitable for conveying delicate materials such as food stuffs.	Forced vibration type with high thrust HD linear motor.	—	60	—	6	—	Base mounted	P.17
Rubber Spring Conveyors	HRC	Variable vibration/low bed type; ideal for light weight and low specific gravity particulate materials.	3-phase induction motor, unbalanced weights, rubber spring resonators.	5~10	5~12	15.8~17.5	6	△	Base mounted	P.19

Note: 1. Vibration-neutralizing effect of MV Conveyor taken as index of 100, and indices for other models based on comparisons with MV Conveyor. Index of (1) for BM model applies when conveyor is mounted on vibration damping springs.  
2. Max. trough length may vary with different trough widths. More information available on request.  
3. ○ indicates approved explosion-proof equipment. △ indicates equipment of equivalent explosion-proof standard.



# MVCB Type Balanced Conveyors

## Simple construction/Anti-vibration

Balanced conveyors are designed to prevent environmental vibration by using a simple structure to prevent vibration from being transmitted to the floor.

An effective balance of trough and counterweight neutralizes vibration, and the equipment is also mounted on vibration-damping springs, minimizing the degree of vibration transmitted to the floor or base.

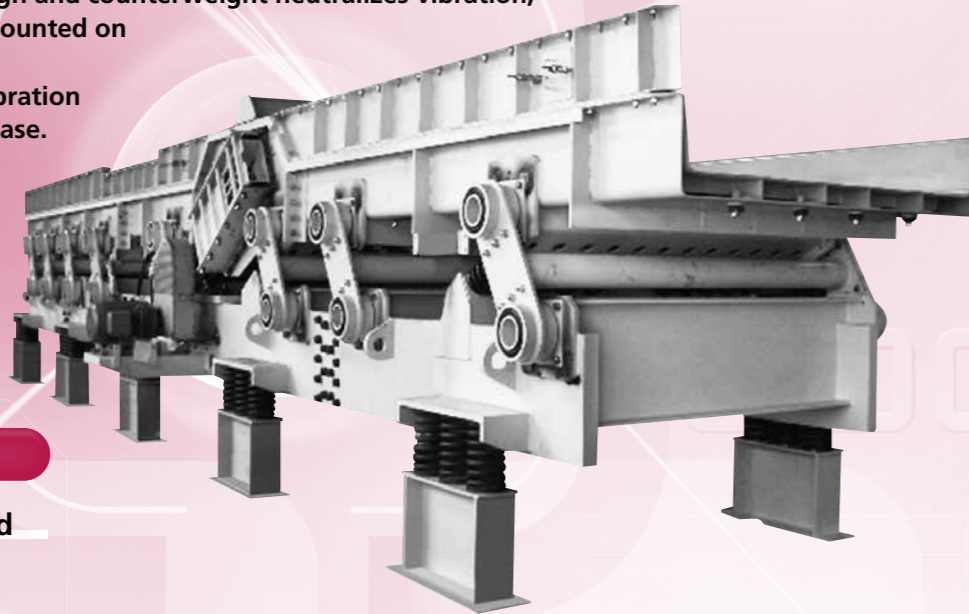

### Features

#### No vibration is transmitted to base or floor

A stable, vibration-neutralizing action prevents vibration from being transmitted to the base or floor, eliminating the need for a special base for installation.

#### Low consumption of electricity

The vibration generated by the eccentric crank action is amplified by resonating springs, therefore the consumption of electricity is very low.

#### Minimal downtime and straightforward servicing and maintenance

The simple structure contains only a few rotating parts, or parts subject to wear. Therefore, servicing and maintenance are straightforward. Basically, however, it's hardly breakdowns anyway.

#### Easily adapted for fully sealed conveyance

The trough can be easily adapted to a fully sealed type, to prevent finely powdered material from dispersal in the air, thus keeping the working environment clean and wholesome.

#### Numerous applications

Processes such as screening, draining, drying and cooling, can be efficiently undertaken during conveyance, making the conveyor suitable for a wide range of applications.

## Construction

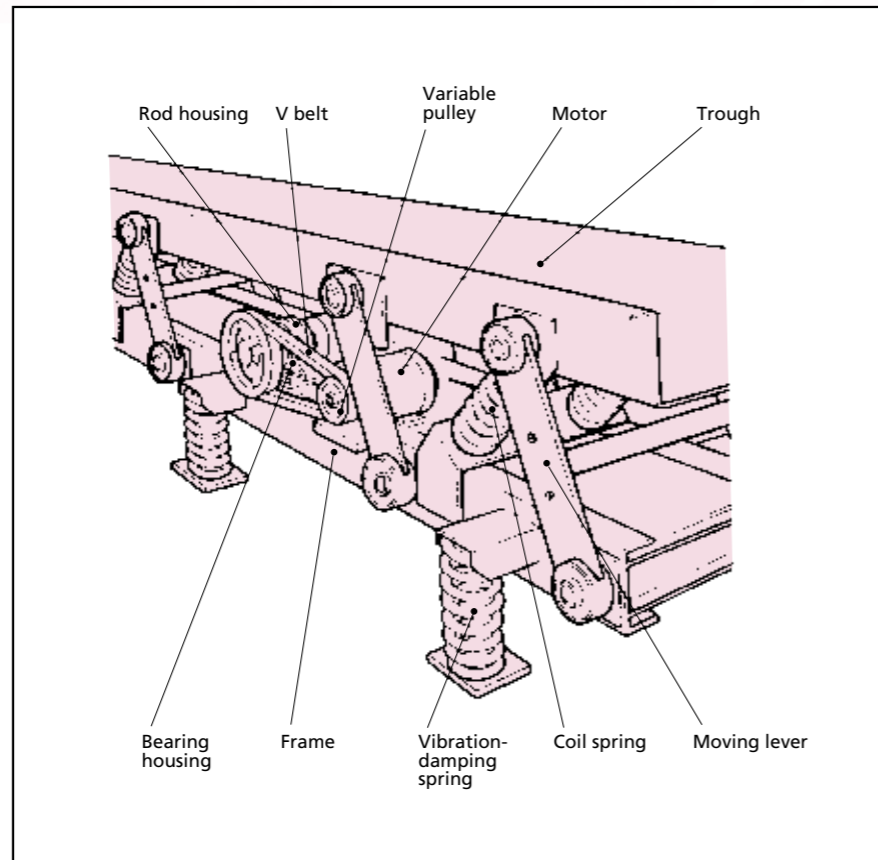

## Specifications

Models	Capacity (t/h)	Vibration frequency (Hz)	Trough length(m)													
			3	4	5	6	8	10	12	15	18	20	25	30		
MVCB-150	5	6.7~10.8	Motor(kW)	1.5	1.5	1.5	1.5	1.5	1.5	1.5	1.5	1.5	2.2	2.2	2.2	3.7
			Overall weight(kg)	440	580	730	870	1160	1450	1740	2180	2610	2900	3630	4360	
MVCB-300	20	6.7~10.8	Motor(kW)	1.5	1.5	1.5	1.5	1.5	1.5	2.2	2.2	3.7	3.7	5.5		
			Overall weight(kg)	670	890	1110	1340	1780	2230	2670	3340	4010	4450	5570	6680	
MVCB-450	35	6.7~10.8	Motor(kW)	1.5	1.5	1.5	1.5	1.5	2.2	2.2	3.7	3.7	5.5	5.5		
			Overall weight(kg)	800	1060	1330	1600	2130	2660	3190	3990	4790	5320	6650	7980	
MVCB-600	50	6.7~10.8	Motor(kW)	1.5	1.5	1.5	1.5	2.2	2.2	3.7	3.7	5.5	5.5	7.5		
			Overall weight(kg)	970	1300	1620	1950	2590	3240	3890	4860	5840	6490	8110	9730	
MVCB-750	65	6.7~10.8	Motor(kW)	1.5	1.5	2.2	2.2	3.7	3.7	5.5	5.5	7.5	7.5	5.5x2	5.5x2	
			Overall weight(kg)	1530	2040	2550	3060	4080	5100	6120	7650	9180	10200	12750	15300	
MVCB-900	80	6.7~10.8	Motor(kW)	1.5	1.5	2.2	2.2	3.7	3.7	5.5	5.5	7.5	7.5	5.5x2	5.5x2	
			Overall weight(kg)	1720	2290	2870	3440	4590	5740	6880	8610	10330	11470	14340	17210	
MVCB-1050	95	6.7~10.8	Motor(kW)	1.5	2.2	2.2	3.7	3.7	5.5	5.5	7.5	7.5	5.5x2	5.5x2	7.5x2	
			Overall weight(kg)	1910	2550	3190	3820	5100	6370	7650	9560	11470	12750	15930	19120	
MVCB-1200	110	6.7~10.8	Motor(kW)	1.5	2.2	2.2	3.7	3.7	5.5	5.5	7.5	7.5	5.5x2	5.5x2	7.5x2	
			Overall weight(kg)	2100	2800	3500	4210	5610	7010	8410	10510	12620	14020	17520	21030	
MVCB-1350	125	6.7~10.8	Motor(kW)	1.5	2.2	3.7	3.7	5.5	5.5	7.5	7.5	5.5x2	5.5x2	7.5x2	7.5x2	
			Overall weight(kg)	2340	3110	3890	4680	6230	7790	9340	11680	14020	15570	19470	23360	
MVCB-1500	140	6.7~10.8	Motor(kW)	2.2	2.2	3.7	3.7	5.5	5.5	7.5	7.5	5.5x2	5.5x2	7.5x2	11x2	
			Overall weight(kg)	2530	3370	4210	5060	6740	8420	10110	12630	15160	16850	21060	25270	
MVCB-1650	155	6.7~10.8	Motor(kW)	2.2	3.7	3.7	3.7	5.5	7.5	7.5	5.5x2	5.5x2	7.5x2	7.5x2	11x2	
			Overall weight(kg)	2760	3680	4600	5520	7350	9200	11040	13800	16560	18390	22990	27590	
MVCB-1800	170	6.7~10.8	Motor(kW)	2.2	3.7	3.7	3.7	5.5	7.5	7.5	5.5x2	5.5x2	7.5x2	7.5x2	11x2	
			Overall weight(kg)	2960	3940	4920	5900	7860	9840	11800	14760	17700	19660	24580	29500	
MVCB-2000	185	6.7~10.8	Motor(kW)	2.2	3.7	3.7	5.5	5.5	7.5	7.5	5.5x2	5.5x2	7.5x2	11x2	11x2	
			Overall weight(kg)	3250	4340	5430	6520	8680	10860	13020	16280	19540	21700	27130	32560	

Notes: 1. Capacity is for conveying sand(apparent specific gravity 1.5, moisture content 4-6%) in a horizontal trough.  
2. Motor capacity and overall mass may vary depending on type of material transported, and use of cover.  
3. Motor capacity and overall mass assume use of cover.

## Dimensions

Unit : mm

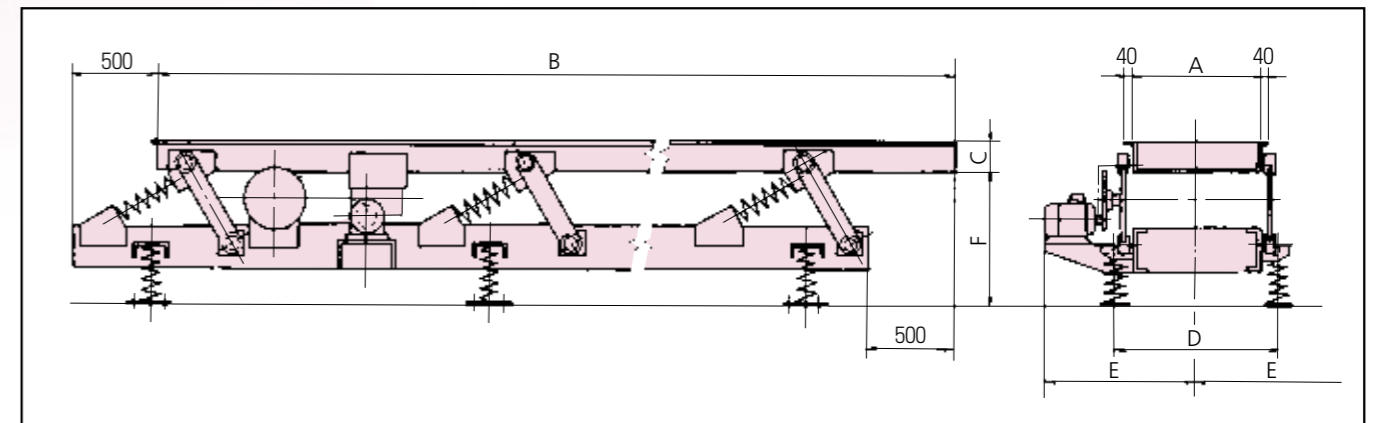

## Dimensions Table

Unit : mm

Models	A	B												C	D	E max	F
MVCB-150	150	3000	4000	5000	6000	8000	10000	12000	15000	18000	20000	25000	30000	140	450	750	600
MVCB-300	300	3000	4000	5000	6000	8000	10000	12000	15000	18000	20000	25000	30000	200	550	800	600
MVCB-450	450	3000	4000	5000	6000	8000	10000	12000	15000	18000	20000	25000	30000	200	700	1000	600
MVCB-600	600	3000	4000	5000	6000	8000	10000	12000	15000	18000	20000	25000	30000	250	850	1100	650
MVCB-750	750	3000	4000	5000	6000	8000	10000	12000	15000	18000	20000	25000	30000	250	1000	1200	700
MVCB-900	900	3000	4000	5000	6000	8000	10000	12000	15000	18000	20000	25000	30000	250	1150	1250	700
MVCB-1050	1050	3000	4000	5000	6000	8000	10000	12000	15000	18000	20000	25000	30000	250	1300	1350	700
MVCB-1200	1200	3000	4000	5000	6000	8000	10000	12000	15000	18000	20000	25000	30000	250	1450	1400	750
MVCB-1350	1350	3000	4000	5000	6000	8000	10000	12000	15000	18000	20000	25000	30000	250	1600	1450	750
MVCB-1500	1500	3000	4000	5000	6000	8000	10000	12000	15000	18000	20000	25000	30000	250	1750	1550	750
MVCB-1650	1650	3000	4000	5000	6000	8000	10000	12000	15000	18000	20000	25000	30000	250	1900	1650	800
MVCB-1800	1800	3000	4000	5000	6000	8000	10000	12000	15000	18000	20000	25000	30000	250	2050	1750	850
MVCB-2000	2000	3000	4000	5000	6000	8000	10000	12000	15000	18000	20000	25000	30000	250	2250	1850	900

Notes: Measure E is reference.

# MVC Type MV Conveyors

## Tough construction/Low cost

MVC conveyors are simple in structure, consisting of a spring-mounted trough vibrated by means of a motor-driven eccentric crank action. Being simple and sturdy, they are ideal for special purposes, such as drying or cooling during conveyance.

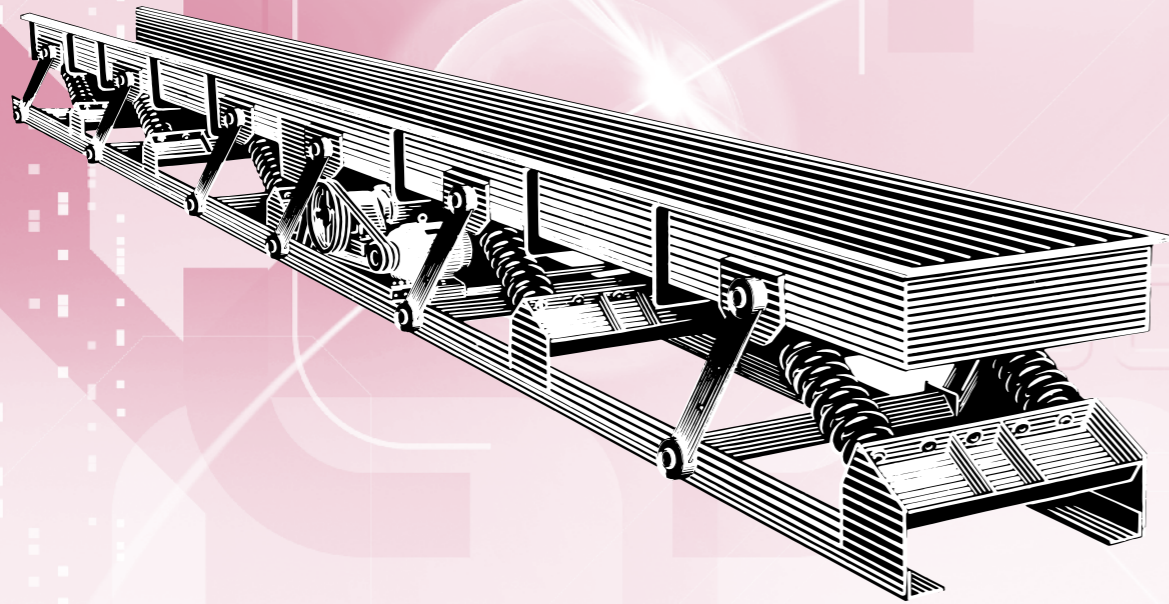

## Specifications

Models	Capacity (t/h)	Vibration frequency (Hz)	Trough length(m)										
			3	4	5	6	8	10	12	15	18	20	
MVC-150	9	6.7~10.8	Motor(kW)	0.75	0.75	0.75	0.75	0.75	1.5	1.5	1.5	1.5	2.2
			Overall weight(kg)	350	430	500	600	730	850	1000	1150	1350	1500
MVC-300	20	6.7~10.8	Motor(kW)	0.75	0.75	0.75	1.5	1.5	1.5	2.2	2.2	2.2	3.7
			Overall weight(kg)	450	550	650	800	950	1100	1300	1550	1800	2000
MVC-450	35	6.7~10.8	Motor(kW)	0.75	0.75	1.5	1.5	1.5	2.2	2.2	2.2	3.7	3.7
			Overall weight(kg)	500	600	750	900	1050	1250	1500	1750	2100	2300
MVC-600	50	6.7~10.8	Motor(kW)	0.75	1.5	1.5	1.5	2.2	2.2	2.2	3.7	3.7	3.7
			Overall weight(kg)	600	700	850	1000	1250	1450	1700	2000	2400	2650
MVC-750	65	6.7~10.8	Motor(kW)	—	1.5	1.5	2.2	2.2	2.2	3.7	3.7	—	—
			Overall weight(kg)	—	850	950	1100	1350	1600	1900	2300	—	—
MVC-900	80	6.7~10.8	Motor(kW)	—	1.5	2.2	2.2	2.2	3.7	3.7	3.7	—	—
			Overall weight(kg)	—	950	1100	1300	1500	1800	2150	2550	—	—
MVC-1050	95	6.7~10.8	Motor(kW)	—	2.2	2.2	2.2	3.7	3.7	3.7	3.7	—	—
			Overall weight(kg)	—	1100	1250	1450	1800	2200	2500	3000	—	—

Notes: 1. Capacity is for conveying sand (apparent specific gravity 1.5, moisture content 4-6%) in a horizontal trough.  
 2. Special configurations may require a different motor model.  
 3. Must be mounted on a firm base as vibration is transmitted through mountings to the floor.

## Features

### Ideal for specialized applications

The perfect equipment for adding processing, such as cooling, drying, draining or selecting, during conveyance.

### Simple structure

The simple structure makes installation, after servicing and maintenance very easy.

### Suitable for long distance conveyance

Assembled in sections that are connected every 5 or 8 meters, this equipment is suited to long distance conveyance.

### Two versions to suit different applications

To reduce impact on the base on which the equipment is mounted, two different systems are available: straight balanced type and parallel balanced type.

## Construction

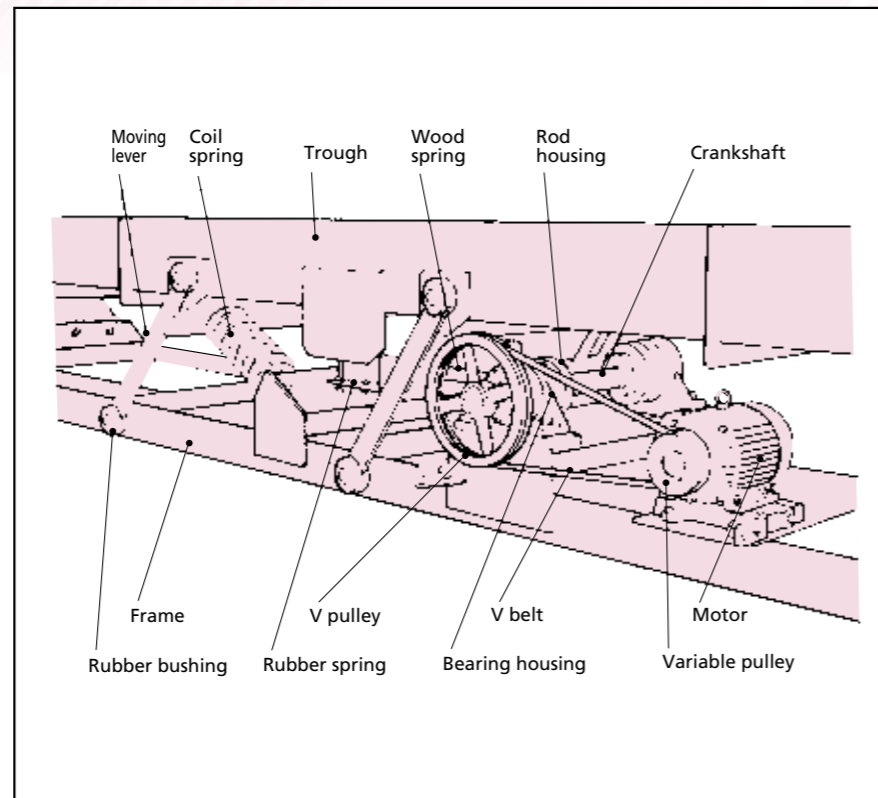

## Dimensions

Unit : mm

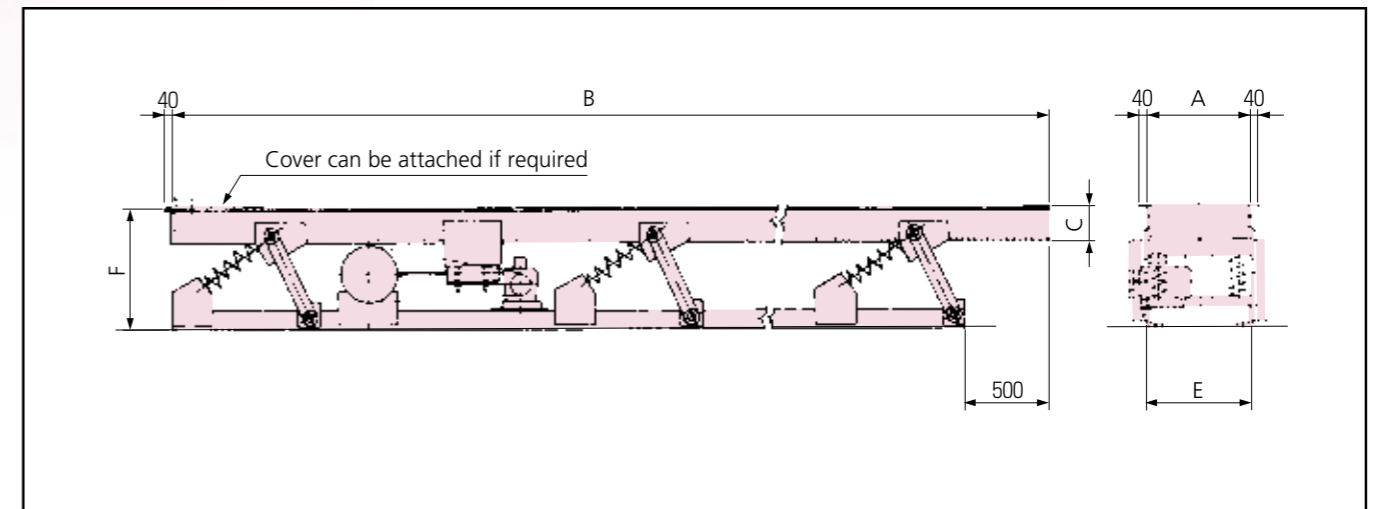

## Dimensions Table

Unit : mm

Models	A	B										C	E	F
MVC-150	150	3000	4000	5000	6000	8000	10000	12000	15000	18000	20000	120	330	610
MVC-300	300	3000	4000	5000	6000	8000	10000	12000	15000	18000	20000	140	300	630
MVC-450	450	3000	4000	5000	6000	8000	10000	12000	15000	18000	20000	180	450	670
MVC-600	600	3000	4000	5000	6000	8000	10000	12000	15000	18000	20000	180	600	670
MVC-750	750	—	4000	5000	6000	8000	10000	12000	15000	—	—	180	750	670
MVC-900	900	—	4000	5000	6000	8000	10000	12000	15000	—	—	180	900	670
MVC-1050	1050	—	4000	5000	6000	8000	10000	12000	15000	—	—	180	1050	670

Note: When installing inlet and outlet, consider B as standard dimension.

# RVF Type RV Conveyors

## Forced-vibration type that can move sticky materials smoothly

RV conveyors, with forced-vibration system, is driven by a RV motor directly attached to the trough. The powerful vibration produced by the motor with unbalanced weight attached to its shaft is directly transferred to the trough.

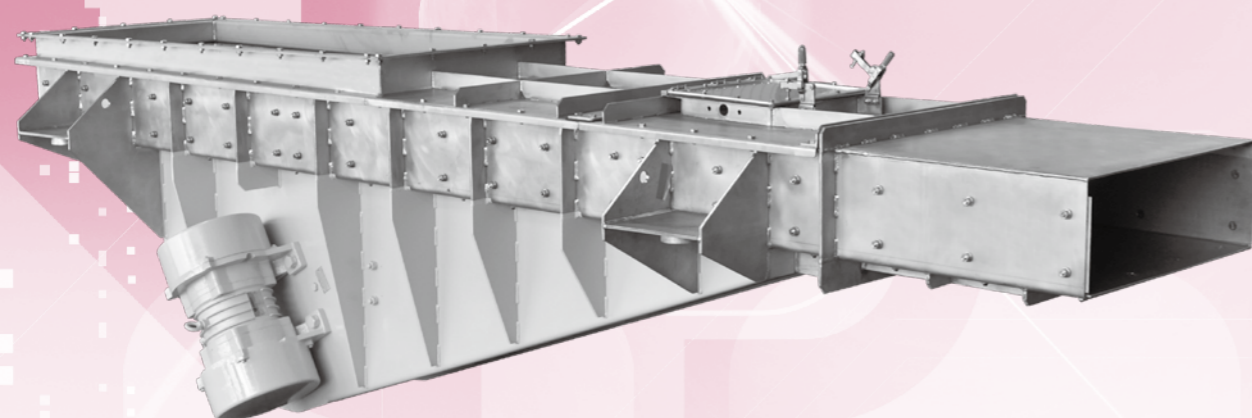

### Dimensions/Specifications

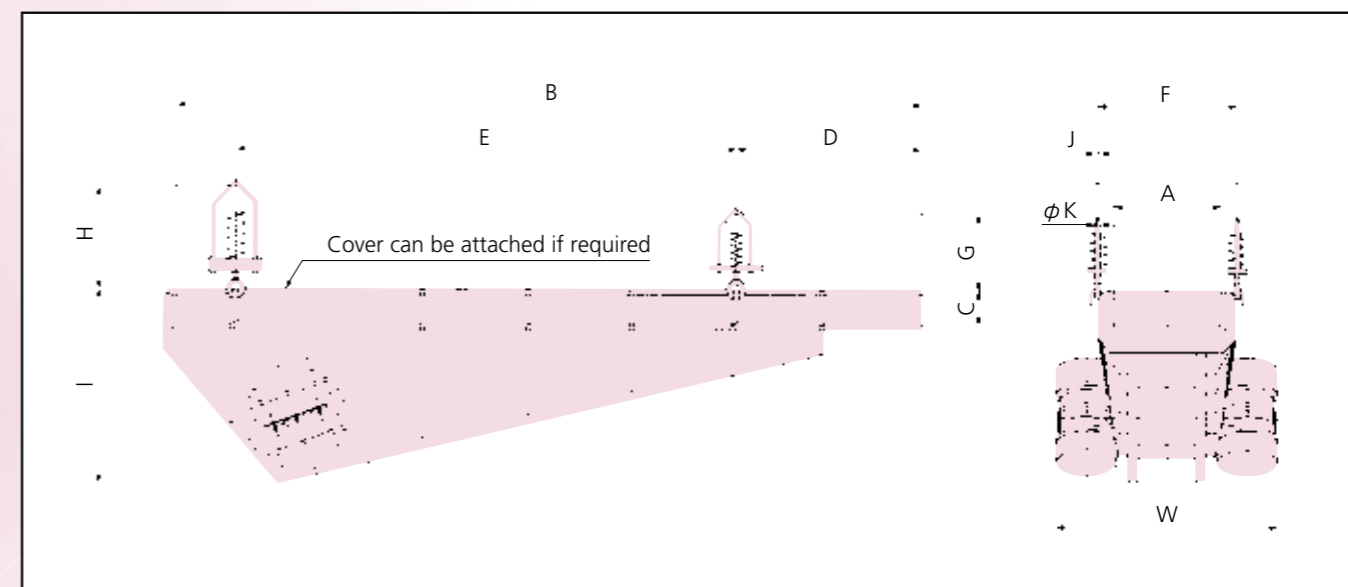

### Features

#### Smooth conveyance of sticky materials

Forced vibration eliminates material adhesion and the resulting over swing, providing stable operation.

#### Adjustable flow rate

Flow rate is easily adjusted by the angle of unbalanced weight at the vibration motor (Adjust the angle when the conveyor is stopped).

#### Best suited for short distance carriage

The conveyor is suitable for short distance carriage up to five meters, such as between equipments.

#### Variety of installing options

The conveyor is commonly installable by suspension, but floor-mounting option and other various installation methods are possible.

### Construction

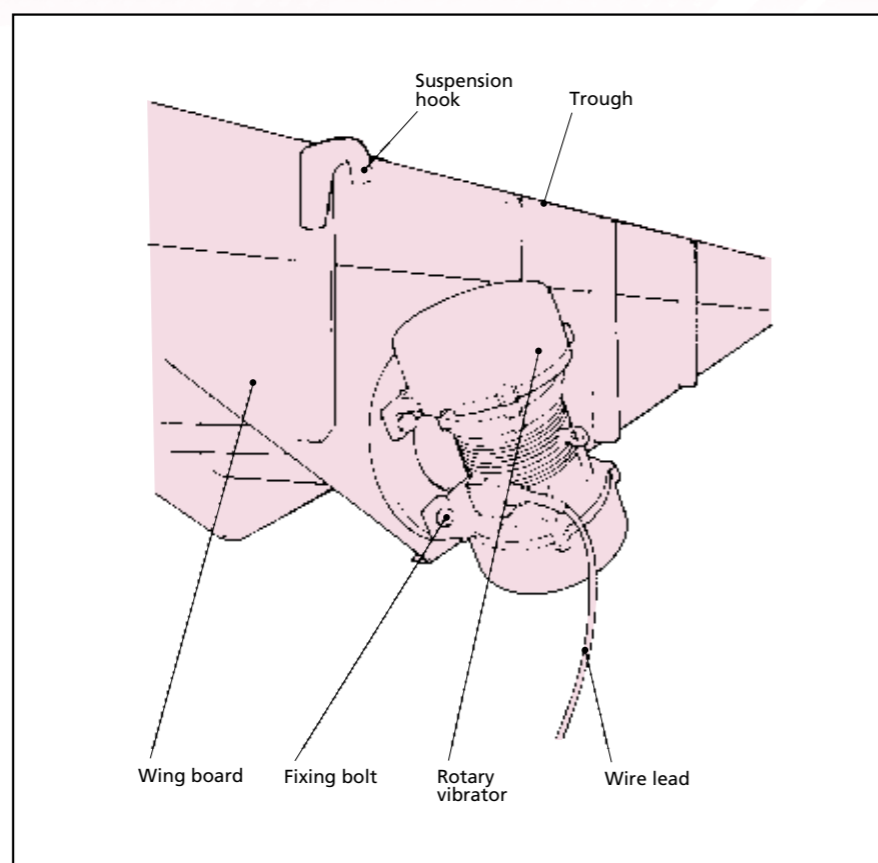

### Specifications/Dimensions Table

Unit : mm

Models	Capacity (t/h)	Vibration frequency (Hz)	Weight (kg)	Rotary vibrator model	A	B	C	D	E	F	G approx	H approx	I approx	J	K	W approx	Recommended controller
RVF-150-1.2	8	24.2/29.2	85	RV-14D	150	1200	100	300	850	248	280	280	460	13	13	550	ORV-14×2R
RVF-150-1.8	8	24.2/29.2	105	RV-14D	150	1800	100	300	1400	248	280	280	540	13	13	550	ORV-14×2R
RVF-150-2.4	8	24.2/29.2	155	RV-24D	150	2400	100	400	1900	248	280	290	540	13	13	580	ORV-24×2R
RVF-150-3.0	8	24.2/29.2	175	RV-24D	150	3000	100	750	2000	248	290	290	600	13	13	580	ORV-24×2R
RVF-300-1.2	15	24.2/29.2	100	RV-14D	300	1200	120	300	850	398	280	280	480	13	13	700	ORV-14×2R
RVF-300-1.8	15	24.2/29.2	155	RV-24D	300	1800	120	300	1400	398	280	290	550	13	13	730	ORV-24×2R
RVF-300-2.4	15	24.2/29.2	185	RV-24D	300	2400	120	400	1900	398	280	290	620	13	13	730	ORV-24×2R
RVF-300-3.0	15	24.2/29.2	210	RV-24D	300	3000	120	750	2000	398	290	400	640	20	13	730	ORV-24×2R
RVF-300-4.0	15	24.2/29.2	285	RV-44D	300	4000	120	850	2900	398	290	420	740	20	13	760	ORV-44×2R
RVF-450-1.2	25	24.2/29.2	140	RV-24D	450	1200	150	300	850	550	280	300	570	13	13	740	ORV-24×2R
RVF-450-1.8	25	24.2/29.2	175	RV-24D	450	1800	150	300	1400	550	300	300	670	13	13	740	ORV-24×2R
RVF-450-2.4	25	24.2/29.2	210	RV-24D	450	2400	150	400	1900	550	300	420	670	20	13	740	ORV-24×2R
RVF-450-3.0	25	24.2/29.2	270	RV-44D	450	3000	150	750	2000	550	300	420	770	20	13	780	ORV-44×2R
RVF-450-4.0	25	24.2/29.2	330	RV-44D	450	4000	150	850	2900	550	420	550	850	30	20	780	ORV-44×2R
RVF-600-1.8	40	24.2/29.2	195	RV-24D	600	1800	150	400	1300	770	310	310	680	13	13	830	ORV-24×2R
RVF-600-2.4	40	24.2/29.2	260	RV-44D	600	2400	150	400	1900	770	310	430	800	20	13	880	ORV-44×2R
RVF-600-3.0	40	24.2/29.2	305	RV-44D	600	3000	150	750	2000	770	430	560	870	30	20	880	ORV-44×2R
RVF-600-4.0	40	24.2/29.2	570	RV-74D	600	4000	150	850	2900	770	560	560	950	30	20	940	ORV-74×2R
RVF-600-5.0	40	24.2/29.2	1080	RV-154B	600	5000	150	900	3700	770	560	560	950	30	20	1110	ORV-154×2R
RVF-750-1.8	60	24.2/29.2	245	RV-44D	750	1800	180	400	1300	920	300	430	750	20	13	960	ORV-44×2R
RVF-750-2.4	60	24.2/29.2	295	RV-44D	750	2400	180	400	1900	920	420	560	870	30	20	960	ORV-44×2R
RVF-750-3.0	60	24.2/29.2	525	RV-74D	750	3000	180	750	2000	920	560	560	950	30	30	1040	ORV-74×2R
RVF-750-4.0	60	24.2/29.2	1025	RV-154B	750	4000	180	850	2900	920	560	560	950	30	30	1210	ORV-154×2R
RVF-750-5.0	60	12.1/14.6	1350	RV-158B	750	5000	180	900	3700	920	580	610	1050	30	30	1270	ORV-158×2R

Notes: 1. Capacity is for conveying sand (apparent specific gravity 1.5, moisture content 4-6%) in a horizontal trough.  
 2. Vibration motor model may vary for special trough.  
 3. Controller is required for vibration motor 8P to avoid counter swing when stopping.  
 4. Floor-mount type can be also manufactured.  
 5. Trough weight is based on an open top, flat bed trough with liner.  
 6. Please refer at small vibrating equipment catalogue (E90-103) for more details of vibrating motor.

## Tubular Trough

The Tubular Trough is ideally suited to materials which require airtight conveyance, or are inclined to generate dust.

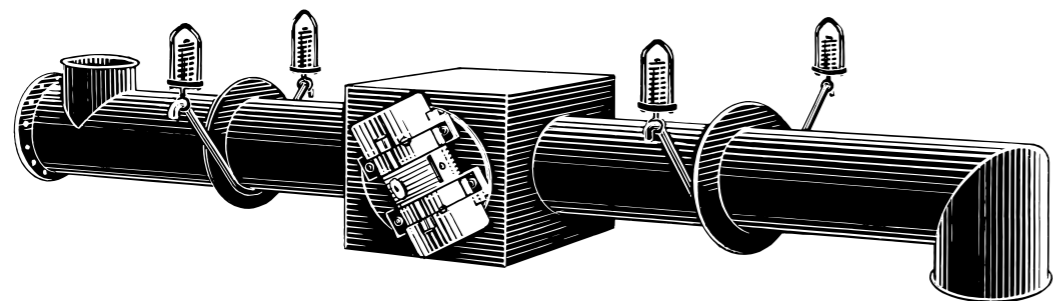

### Dimensions/Specifications

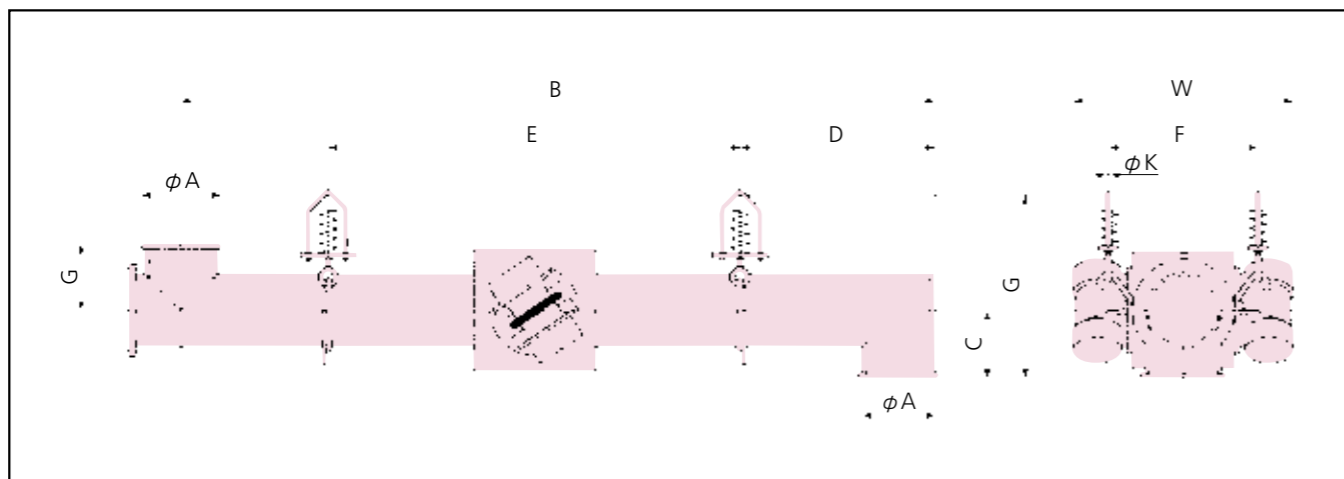

### Specifications/Dimensions Table

Unit : mm

Models	Capacity (t/h)	Vibration frequency (Hz)	Weight (kg)	Rotary vibrating model	A	B	C	D	E	F	G approx	W approx	K	Recommended controller
RVF-φ150-1.8	7	24.2/29.2	90	RV-14D	165	1600	150	250	1100	400	560	700	13	ORV-14×2R
RVF-φ150-2.4	7	24.2/29.2	150	RV-24D	165	2200	150	250	1700	400	560	800	13	ORV-24×2R
RVF-φ200-1.8	12	24.2/29.2	180	RV-24D	216	1500	200	250	1000	450	610	850	13	ORV-24×2R
RVF-φ200-2.4	12	24.2/29.2	240	RV-44D	216	2100	200	250	1700	450	620	900	13	ORV-44×2R
RVF-φ200-3.0	12	24.2/29.2	270	RV-44D	216	2700	200	300	2300	450	620	900	13	ORV-44×2R
RVF-φ300-2.4	25	24.2/29.2	270	RV-44D	318	2000	250	300	1400	650	720	1000	13	ORV-44×2R
RVF-φ300-3.0	25	24.2/29.2	390	RV-74D	318	2600	250	350	1900	650	740	1150	13	ORV-74×2R
RVF-φ300-4.0	25	12.1/14.6	450	RV-78B	318	3600	250	650	2300	650	740	1150	13	ORV-78×2R
RVF-φ300-5.0	25	12.1/14.6	550	RV-78B	318	4600	250	650	3300	650	750	1200	13	ORV-78×2R
RVF-φ400-2.4	40	24.2/29.2	410	RV-74D	406	1900	300	300	1250	800	840	1250	13	ORV-74×2R
RVF-φ400-3.0	40	24.2/29.2	450	RV-74D	406	2500	300	400	1700	800	840	1250	13	ORV-74×2R
RVF-φ400-4.0	40	12.1/14.6	550	RV-78B	406	3500	300	500	2500	800	850	1300	13	ORV-78×2R
RVF-φ400-5.0	40	12.1/14.6	800	RV-158B	406	4500	300	500	3500	800	950	1500	20	ORV-158×2R

- Notes: 1. Capacity is for conveying sand(apparent specific gravity 1.5, moisture content 4-6%) in a horizontal trough.  
 2. Troughs with specialized specifications may require a different vibration motor model.  
 3. Controller is required for vibration motor 8P to avoid counter swing when stopping.  
 4. Please refer at small vibrating equipment catalogue (E90-103) for more details of vibrating motor.

# RVES Type Spiral Elevators

### Space saving/Vertical lift

SINFONIA's Spiral Elevators combine a drive mechanism and a vertically aligned, spiral-shaped trough, which vibrates to drive particulate materials to the top. Suitable for all types of materials, it can also be used for downward conveyance. Simultaneous drying and cooling processes can be accommodated.

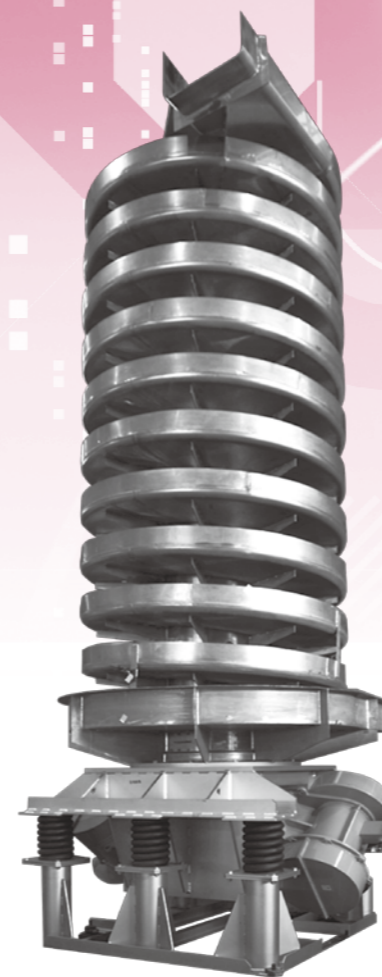

### Features

#### Economical on space

Because of its vertical orientation, very little floor area is taken up, and the spiral trough is compact in shape. Trough surface area is relatively large, and can be fully utilized.

#### Can be used for cooling and drying

Cooling or drying can be accomplished by means of natural air flow created by temperature gradient, an applied flow of air, or alternatively by natural drying over time in the trough.

#### Smooth conveyance

Ideal for materials difficult to handle with a bucket or belt conveyor, as well as spherical particles.

#### Provides conveyance at a fixed rate

The conveyance speed is constant and so standardized quantities can be continuously transported.

#### Flow easily adjustable

The flow of material can be easily controlled by adjusting the unbalanced weight of the rotary vibrator.

#### Creates no dust

Conveyance creates minimal dust, even with materials of extremely low apparent specific gravity.

#### Special structure

For a fully sealed, anti-dust conveyor, a transparent cover can be fitted which allows inspection during transport.

#### Easy maintenance

The drive mechanism is compact and the trough is not subject to wear. Maintenance is therefore straightforward and fast.

### Dimensions

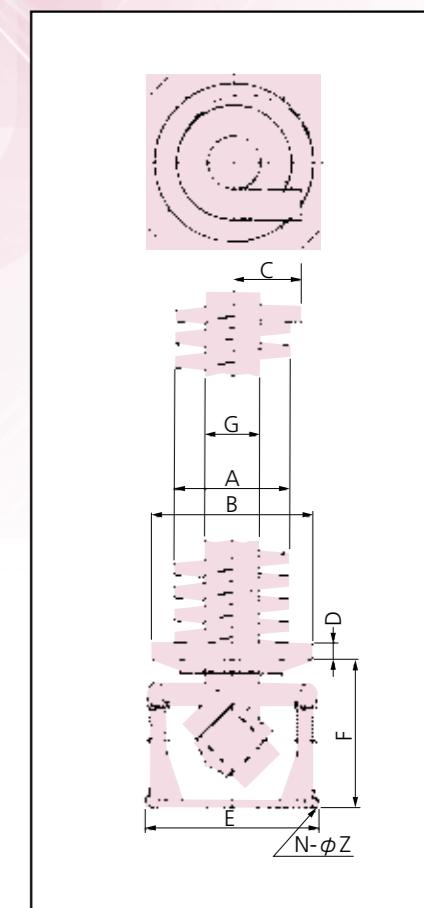

### Specifications/Dimensions Table

Unit : mm

Models	Capacity (t/h)	Vibration motor			Lift (m)	Weight (kg)	A	B	C	D	E	F	N-Z	G	Recommended controller	
		Models	Output (kW)	No. of poles												Number
RVES-500-1.5	2.5	RV-44D	0.4	4	2	1.5	300	500	750	280	50	600	610	4-15	268	ORV-44×2R
RVES-650-3	4	RV-78B	0.75	8	2	3	650	650	1000	350	80	900	880	4-15	318	ORV-78×2R
RVES-780-4.5	5	RV-158B	1.5	8	2	4.5	1000	780	1100	420	100	1100	950	8-15	406	ORV-158×2R
RVES-860-6	6	RV-228B	2.2	8	2	6	1500	860	1200	450	120	1300	1100	8-18	457	ORV-228×2R
RVES-1000-7.5	8	RV-378B	3.7	8	2	7.5	2000	1000	1400	550	150	1500	1350	8-18	508	ORV-378×2R
RVES-1200-8.5	10	RV-558B	5.5	8	2	8.5	3000	1200	1600	670	170	1700	1400	10-18	610	ORV-558×2R
RVES-1500-10	12	RV-758B	7.5	8	2	10	4000	1500	2000	800	200	2000	1450	10-18	711	ORV-758×2R
RVES-2000-5.6	20	RV-5512B	5.5	12	2	5.6	8000	2000	2600	1400	300	2500	1800	14-23	1000	-

- Notes: 1. Capacity is for conveying sand(apparent specific gravity 1.5, moisture content 4-6%) in a horizontal trough.  
 2. Please refer at small vibrating equipment catalogue (E90-103) for more details of vibrating motor.

### For RV and RVES

Starts and stops at the touch of a button. When stopping, the rotary vibrating automatically switches into negative phase and the conveyor comes to an immediate stop. This prevents shaking and overflow of the material. Negative phase timing can be controlled with a timer, for perfect stops with the ideal duration of negative phase.



### Dimensions/Specifications

Unit : mm

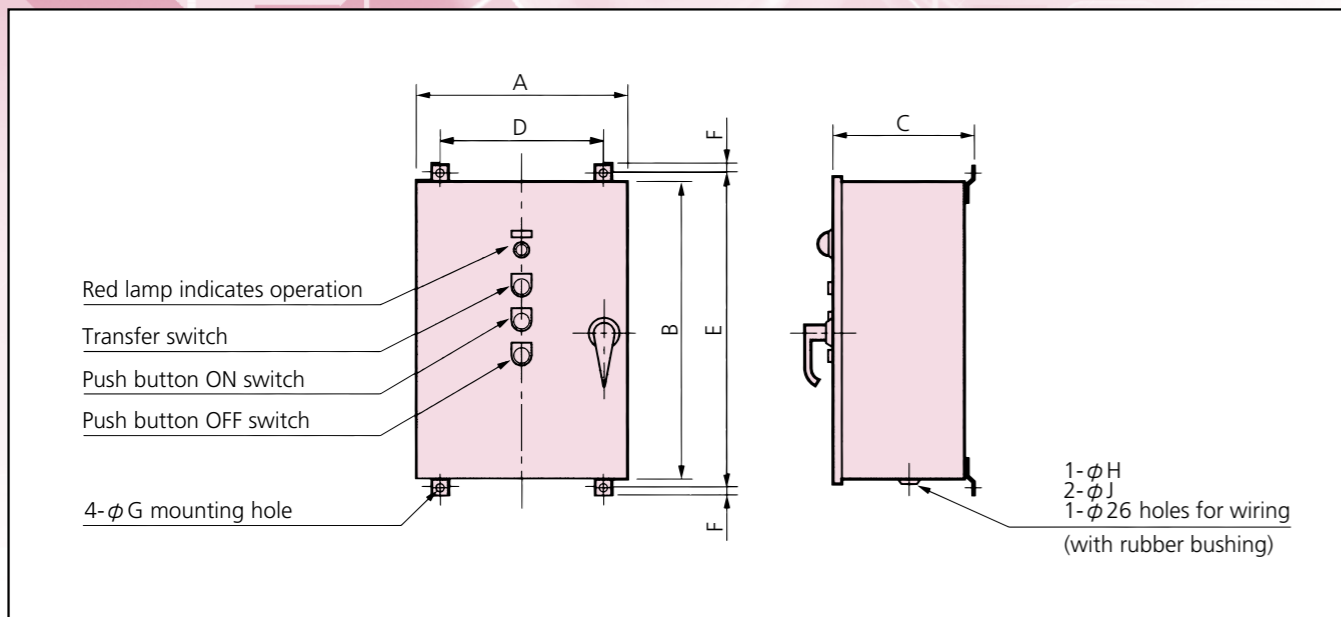

### ● Specifications/Dimensions Table

Models	Dimensions(mm)									Typical rating (50/60Hz)		Weight (kg)	Compatible motor size
	A	B	C	D	E	F	G	H	J	Current capacity(A)			
										200/220V	400/440V		
ORV-14×2R	400	500	220	300	540	15	11	26	26	3/2	—	20	RV-14D
ORV-24×2R	400	500	220	300	540	15	11	26	26	5/3	—	20	RV-24D
ORV-44×2R	400	500	220	300	540	15	11	26	26	6/4	—	20	RV-44D
ORV-74×2R	400	500	220	300	540	15	11	26	26	9/5	—	20	RV-74D
ORV-154×2R	450	600	220	350	640	20	14	26	26	15/8	—	30	RV-154B
ORV-224×2R	450	600	220	350	640	20	14	26	26	21/11	—	30	RV-224B
ORV-78×2R	400	500	220	300	540	15	11	26	26	10/6	—	20	RV-78B
ORV-158×2R	450	600	220	350	640	20	14	26	26	19/10	—	30	RV-158B
ORV-228×2R	450	600	220	350	640	20	14	26	26	17/9	—	30	RV-228B
ORV-378×2R	500	800	270	400	840	20	14	42	26	27	—	60	RV-378B
ORV-378×2R	450	600	220	350	640	20	14	26	26	—	14	30	RV-378B
ORV-558×2R	500	800	270	400	840	20	14	42	26	31	—	60	RV-558B
ORV-558×2R	450	600	220	350	640	20	14	26	26	—	16	30	RV-558B
ORV-758×2R	500	800	270	400	840	20	14	42	42	41/21	—	60	RV-758B

Notes: 1. Ratings are all continuous. 2. Dust-resistant casing, for mounting on interior wall. 3. Painted inside and out in Munsell 5Y7/1.

### High-amplitude conveyors driven by electromagnet

MDC type conveyors is a revolutionary vibration conveyor which is driven by electromagnetic force designed by SINFONIA, which realizes high-amplitude conveyance without vibration generators like conventional vibrating conveyors. The compact, low noise, and maintenance-free conveyor, with purpose-built controller that can easily adjust amplitude, suits best for applications in food, pharmaceutical, and chemical processing.



### Features

#### No vibration motor required

Electromagnetic drive uses electromagnetic force to generate vibration and does not require conventional motors.

#### Easy maintenance

Electromagnetic drive decreases the number of wearing and degrading components required for maintenance and maintenance is easy.

#### Purpose-built controller

Multi-function controller is included as a standard, enabling selection of operating mode, control of vibration amplitude, and realization of efficient conveyance.

#### Simple body

Low-height and simple structure offers installation versatility at factories.

#### Low noise, low reaction force

Maximum of 60dB (no load) noise from the system, much lower than conventional conveyors. Low reaction force to floor provides better working condition.

### Construction

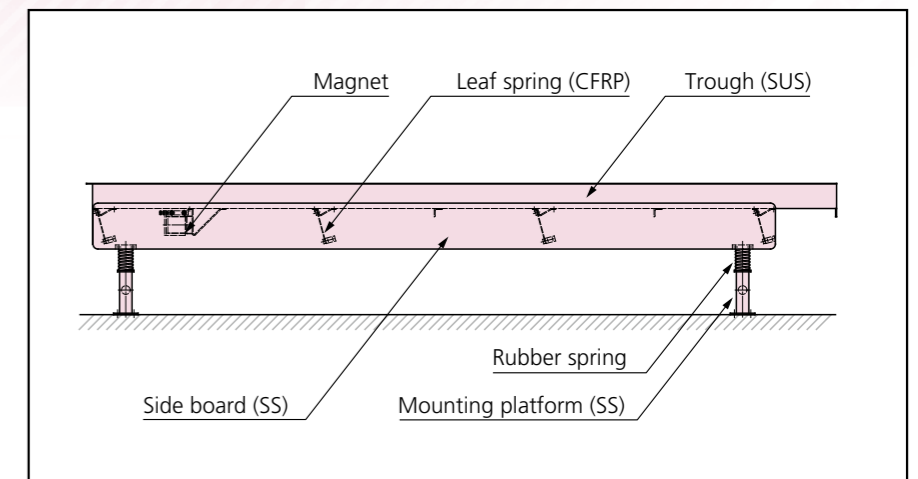

### Specifications

Amplitude	4 – 6mm
Vibration frequency	20 – 25Hz
Controller	C10 –15VFEF
Voltage	AC200 / 220V10%
Frequency	50 / 60Hz
Current	Maximum 15A



# MDC Controller C10-15VFEF

## Dimensions

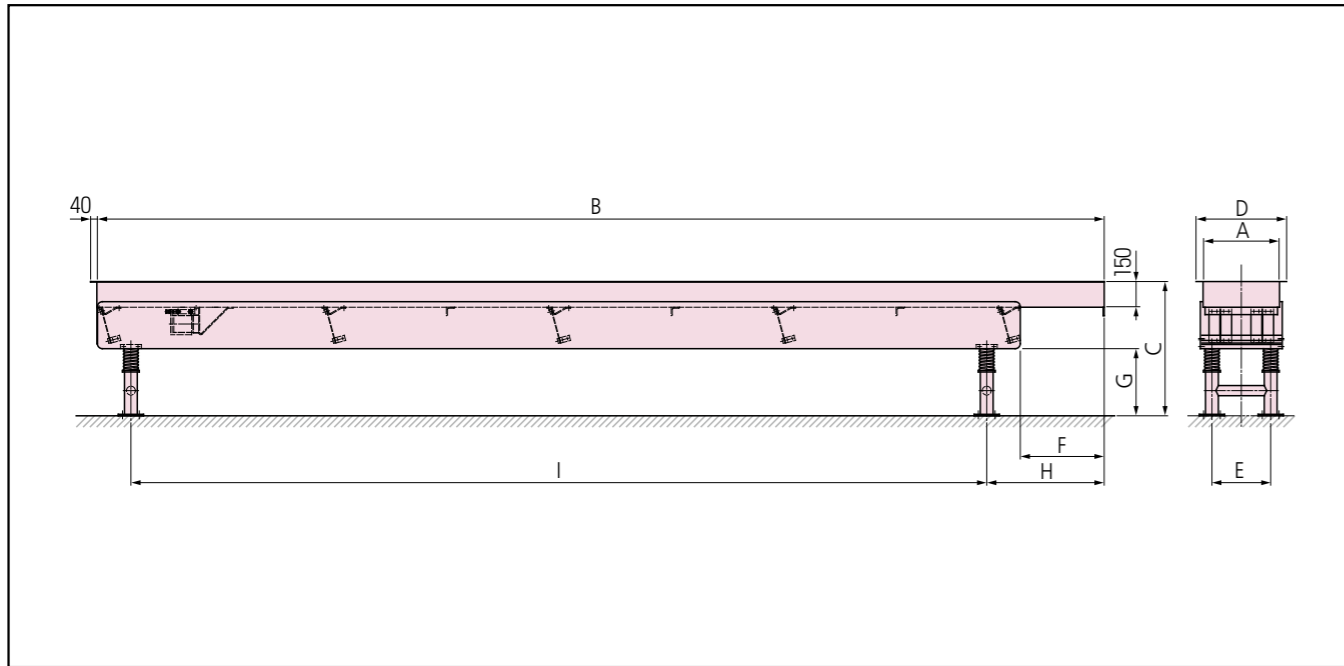

### ●Dimensions Table

Models	Dimensions(mm)									Weight(kg) SUS
	A	B	C	D	E	F	G	H	I	
MDC-300-3	300	3000	800	390	200	500	400	700	2100	300
MDC-300-4	300	4000	800	390	200	500	400	700	3100	400
MDC-300-5	300	5000	800	390	200	500	400	700	4100	500
MDC-300-6	300	6000	800	390	200	500	400	700	5100	600
MDC-450-3	450	3000	800	540	350	500	400	700	2100	340
MDC-450-4	450	4000	800	540	350	500	400	700	3100	440
MDC-450-5	450	5000	800	540	350	500	400	700	4100	540
MDC-450-6	450	6000	800	540	350	500	400	700	5100	640
MDC-600-3	600	3000	800	690	500	500	400	700	2100	380
MDC-600-4	600	4000	800	690	500	500	400	700	3100	480
MDC-600-5	600	5000	800	690	500	500	400	700	4100	580
MDC-600-6	600	6000	800	690	500	500	400	700	5100	680
MDC-750-3	750	3000	800	840	650	500	400	700	2100	420
MDC-750-4	750	4000	800	840	650	500	400	700	3100	520
MDC-750-5	750	5000	800	840	650	500	400	700	4100	620
MDC-750-6	750	6000	800	840	650	500	400	700	5100	720

## Multi-function controller for optimum control of electromagnetic conveyors

Purpose-built controller for electromagnetic conveyor has multiple functions including auto-tuning, constant amplitude control, constant voltage control, external volume connection, etc. Optimum operating mode is selectable according to the varying factors of material properties and feeding volume. Output frequency is adjustable to match driving system, eliminating the need for delicate adjustment of leaf springs.



## Dimensions

Unit : mm

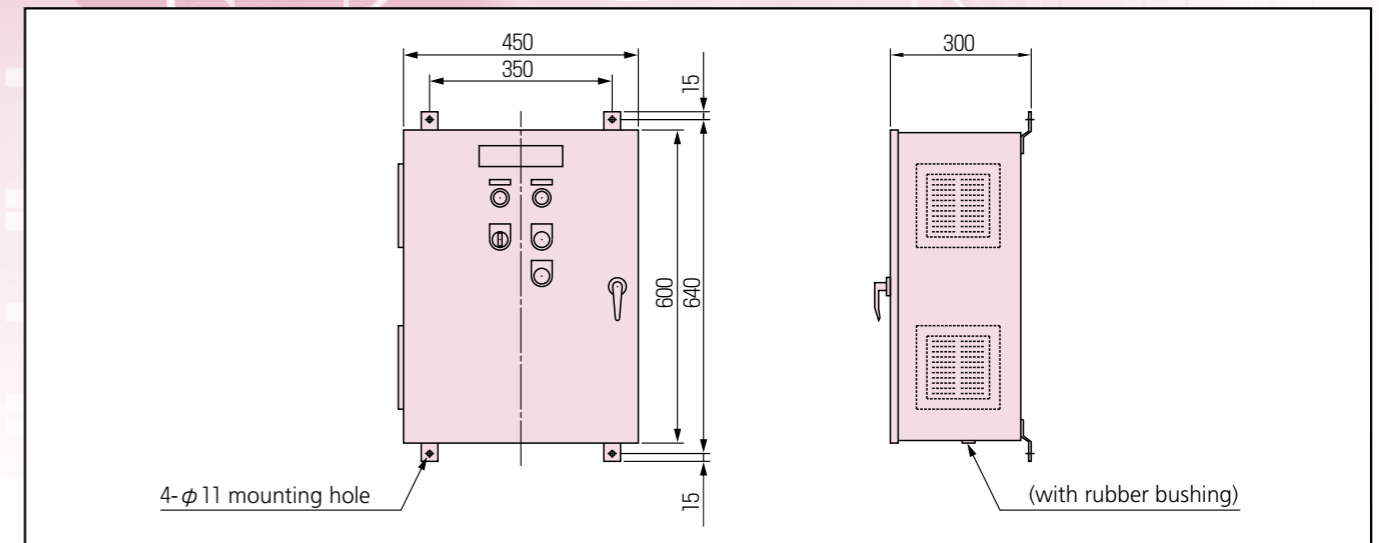

## Specifications

Input power supply	AC200 / 220V ± 10% 50 / 60Hz	
Control	PWM method	
Output	Voltage	0 - 95%
	Vibration frequency	Half-wave drive 45 - 65Hz (Half drive 18 - 30Hz)
	Max. current	15A
Operation mode	Auto-tuning	Constant amplitude control without frequency setting by resonance point-following function
	Constant amplitude	Constant amplitude control by frequency setting
	Constant voltage	Constant voltage control by frequency setting
	ON/OFF control	ON/OFF control by external signal
	Dual control	Amplitude setting switchover by external signal
Additional function	Remote signal input	Amplitude adjustment (output voltage adjustment) by DC4 - 20mA input
	External volume connection	Maximum of 2 amplitude adjuster volume are connectable
	Output signal	Relay output of operating signal and alarm signal
	Meter output	Signal output to amplitude indicator
	Soft start	Rising time 0.2 - 2.0 second
Protection function	Overcurrent detection	Prevention of device damage caused by overcurrent
	Overvoltage detection	Monitoring of excess and deficiency of input voltage
	Sensor disconnection detection	Detection of wire disconnection during amplitude sensor in operation
Structure	Indoor, dust-proof, wall-mount	
Weight	40kg	

# HDC Type Slide Conveyors

## Linear motor driven horizontal vibrating conveyor

The world first conveyor with horizontal vibration, driven by HD linear motor, a revolutionary drive source, realizes excellent conveying performance with delicate, silent, low pollution motion. The innovative system may totally change the conventional powder and particle conveyance including food and chemical applications.

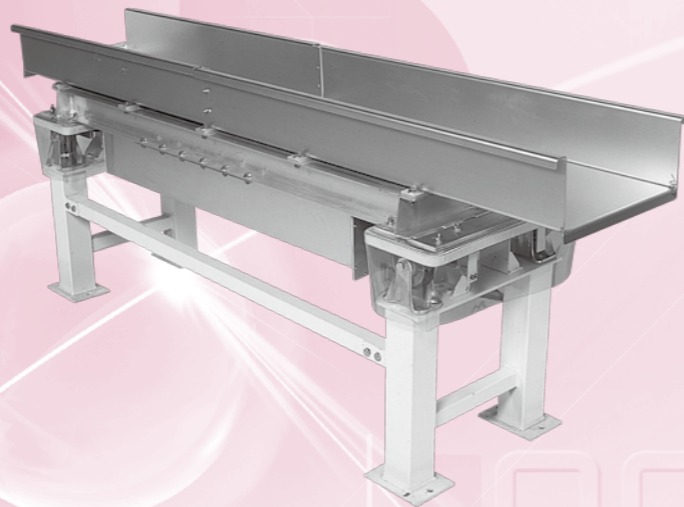

### Specifications/Dimensions

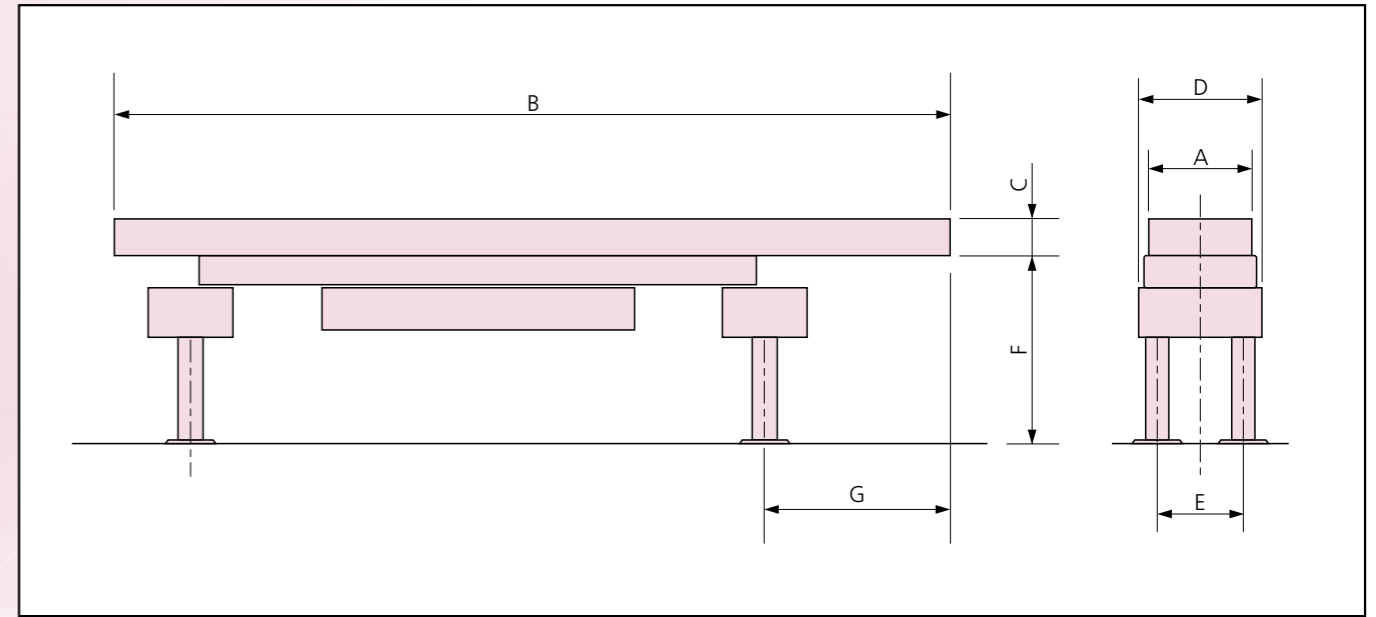

### Features

#### Soft, delicate transport of materials

Unlike conventional up-down vibration, the conveyor slides materials on the trough surface by repeated horizontal movement. Its delicate handling is widely applicable to fragile, light-weight, or thin materials. The system carries materials evenly with less segregation, an advantage in food processing to avoid seasoning loss.

#### Low impact noise conveyance

Materials move as if sliding on trough surface, creating quiet low impact and noise between them. Vibrating frequency and amplitude are adjustable according to materials.

#### Easy switchover of forward and backward movement

Linear motor provides free forward and backward conveyance of materials during processing and can be freely switched between them when required.

#### Low reactive force to floor

Horizontal vibration with low vertical reactive force eliminates vibratory problems to floor and surrounding equipment.

#### Adjustable capacity (speed)

Conveyor speed is freely adjustable in a range from zero to maximum continuously, enabling the selection of best timing for each material and process.

#### Large over-hung installable

Larger over-hung in front and back of the trough than conventional vibration conveyor is installable.

### Construction

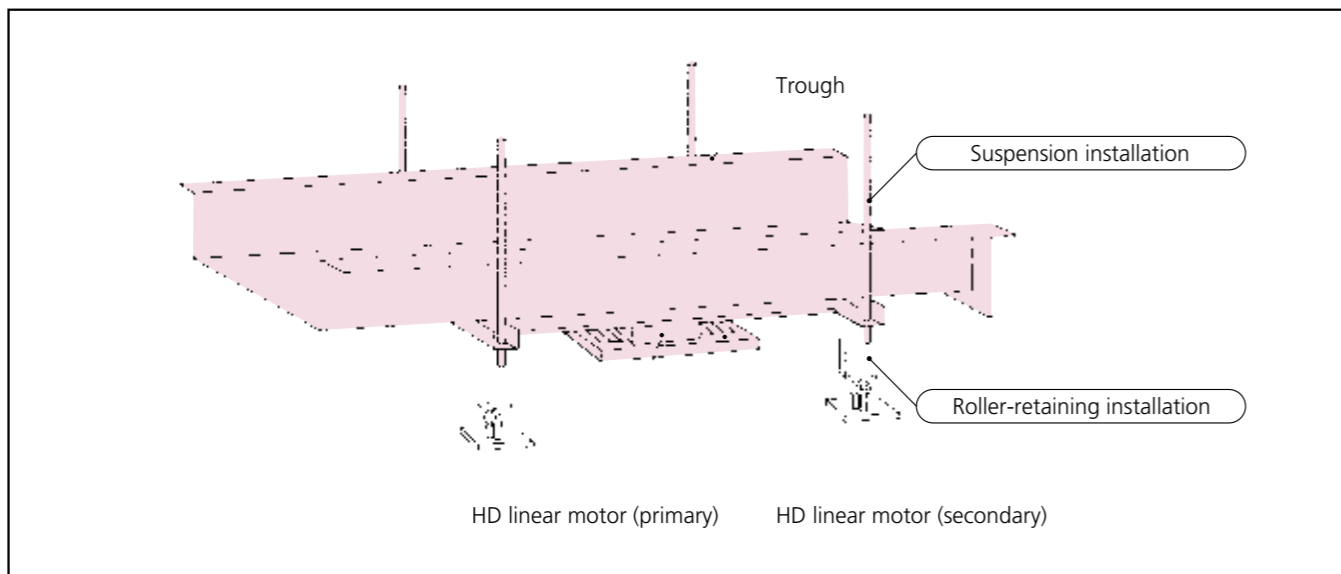

### Specifications/Dimensions Table

Models	Weight(kg)		Dimensions(mm)							Power supply capacity/ Power consumption	
	Aluminum trough	SUS/SS trough	A	B	C	D	E	F	G	Aluminum trough	SUS/SS trough
HDC-300-3	300	320	300	3000	150	390	300	375	400	3kVA/700W 200/220V 50/60Hz	
HDC-300-4	310	350	300	4000	150	390	300	375	400		
HDC-300-5	330	400	300	5000	150	450	300	375	400		
HDC-300-6	345	450	300	6000	180	450	300	375	400		
HDC-450-3	315	350	450	3000	150	560	450	375	450		
HDC-450-4	335	380	450	4000	150	560	450	375	450		
HDC-450-5	355	410	450	5000	150	600	450	400	450		
HDC-450-6	370	567	450	6000	180	600	450	400	450		
HDC-600-3	325	400	600	3000	180	720	600	375	500		
HDC-600-4	345	440	600	4000	180	720	600	400	500		
HDC-600-5	370	600	600	5000	180	750	600	400	500		
HDC-600-6	390	670	600	6000	220	750	600	400	500		
HDC-750-3	335	420	750	3000	200	900	750	400	500		
HDC-750-4	360	585	750	4000	200	900	750	400	500		
HDC-750-5	380	640	750	5000	200	920	750	400	500		
HDC-750-6	405	730	750	6000	250	920	750	400	500		
HDC-900-3	360	720	900	3000	200	1050	900	400	500		
HDC-900-4	390	730	900	4000	200	1050	900	400	500		
HDC-900-5	440	760	900	5000	200	1070	900	400	500		
HDC-900-6	570	790	900	6000	250	1070	900	400	500		

Note: Provide power supply of 200/220V.

# HRC Type Rubber Spring Conveyors

## Variable vibration angle/low bed

Rubber spring conveyors are low-bed conveyors in which the trough angle of vibration can be freely adjusted to match the material and its conveyance requirements, which was difficult for conventionals.

Circular vibration is generated by an unbalanced weight driven by a motor, and is amplified by means of resonating rubber springs with variable angles of vibration, to provide uniform, stable vibration throughout the trough.

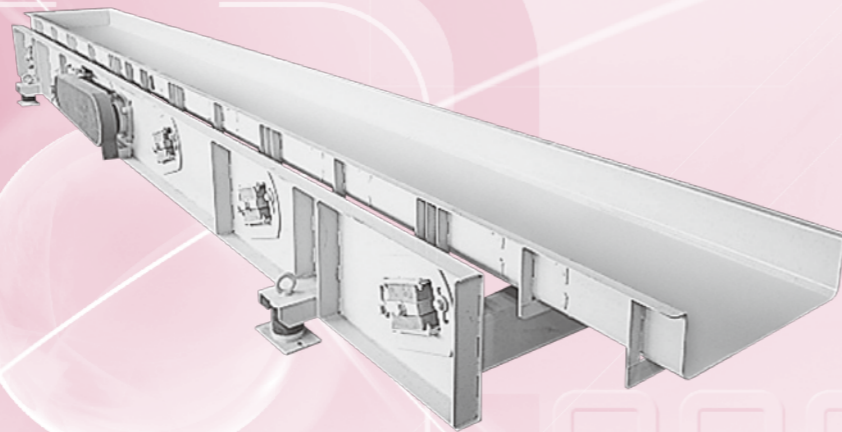

## Features

### Vibration angle can be adapted to match material

In contrast to former conveyors, the angle of the vibration-resonating rubber springs can be easily adjusted to provide the ideal vibration for the type of material to be transported.

### Small size but large capacity

With increased vibration frequency (max.17.5Hz/sec) and a variable angle of vibration, the HRC model offers greater vibration magnitude (max.12mm), and therefore has double the conveyance capacity of former vibrating conveyors. This high performance conveyor is therefore able to move volumes never previously possible with such small-sized equipment.

### Facilitates manual selecting work

For manual selecting work, the trough vibration magnitude and the conveyance speed can be easily adjusted to provide a level of vibration that minimizes bouncing, and thus reduces strain on the eyes.

### Low height/low bed type

The light-weight steel base frame and trough are coupled together by specially designed rubber springs for a lower bed and lower overall height.

### Vibration dampers reduce noise

The use of vibration resonators means that a small vibration source can produce a large vibrating effect. Vibration of the frame is minimal, and the frame is itself mounted on vibration-absorbing springs. Thus, only the tiniest degree of vibration is

transmitted to the floor or base, and operation of the conveyor creates very little noise.

### Straightforward servicing and maintenance

Construction is simple and parts such as rubber springs, bearings etc. are all attached separately from the outside, for straightforward servicing, maintenance and parts replacement.

### Fully adaptable for low or high speed conveyance

A special control mechanism allows free adjustment of trough vibration frequency, giving an unlimited choice within a wide range of conveyance speeds.

## Construction

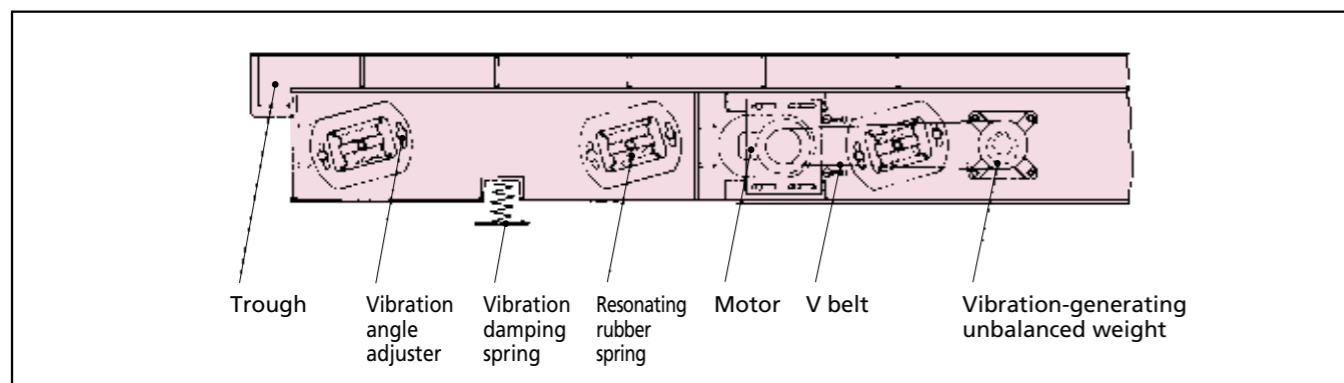

## Specifications

Models	Capacity (t/h)	Vibration frequency (Hz)	Trough length(m)				
			3	4	5	6	
HRC 200	10	15.8~17.5	Motor (kW)	0.75	0.75	1.5	1.5
			Overall weight(kg)	300	400	500	600
HRC 300	15	15.8~17.5	Motor (kW)	0.75	1.5	1.5	1.5
			Overall weight(kg)	350	450	550	650
HRC 450	20	15.8~17.5	Motor (kW)	1.5	1.5	1.5	2.2
			Overall weight(kg)	450	550	650	850
HRC 600	30	15.8~17.5	Motor (kW)	1.5	1.5	2.2	2.2
			Overall weight(kg)	600	700	900	1050
HRC 750	40	15.8~17.5	Motor (kW)	2.2	2.2	3.7	3.7
			Overall weight(kg)	700	900	1100	1350
HRC 900	50	15.8~17.5	Motor (kW)	2.2	3.7	3.7	3.7
			Overall weight(kg)	900	1100	1300	1500

Notes: 1. Standard trough is open, without cover or liner.  
 2. Capacity is for conveying granulated sugar(apparent specific gravity 0.8, moisture content 0.05%) in a horizontal trough.  
 3. Motor capacity and overall weight may vary depending on type of material conveyed, and use of cover or liner.

## Dimensions

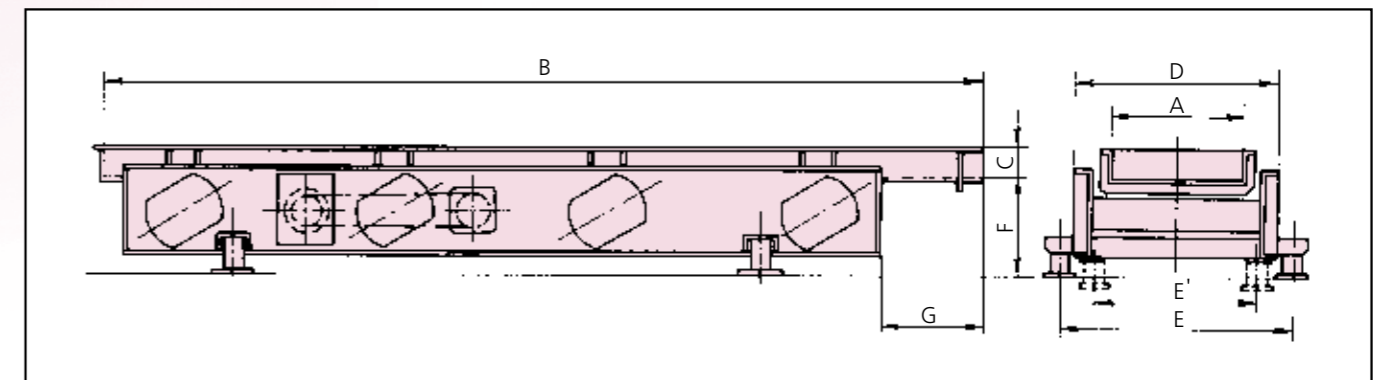

### Dimensions Table

Models	A	B	C	D	E	E'	F	G
HRC 200-3	200	3000	150	380	—	270	450	400
HRC 200-4	200	4000	150	380	520	—	400	400
HRC 200-5	200	5000	150	380	520	—	400	400
HRC 200-6	200	6000	180	380	520	—	400	400
HRC 300-3	300	3000	150	480	—	370	450	400
HRC 300-4	300	4000	150	480	620	—	400	400
HRC 300-5	300	5000	150	480	620	—	400	400
HRC 300-6	300	6000	200	480	620	—	400	400
HRC 450-3	450	3000	150	655	—	550	480	450
HRC 450-4	450	4000	150	655	800	—	400	450
HRC 450-5	450	5000	180	655	850	—	400	450
HRC 450-6	450	6000	200	700	900	—	400	450
HRC 600-3	600	3000	180	850	—	700	620	500
HRC 600-4	600	4000	180	850	1050	—	430	500
HRC 600-5	600	5000	180	850	1050	—	430	500
HRC 600-6	600	6000	220	850	1050	—	430	500
HRC 750-3	750	3000	200	1010	—	850	620	500
HRC 750-4	750	4000	200	1010	1200	—	450	500
HRC 750-5	750	5000	200	1010	1200	—	450	500
HRC 750-6	750	6000	250	1010	1200	—	450	500
HRC 900-3	900	3000	200	1165	—	1000	620	500
HRC 900-4	900	4000	200	1165	1350	—	450	500
HRC 900-5	900	5000	200	1165	1350	—	450	500
HRC 900-6	900	6000	250	1165	1350	—	450	500

Unit : mm

# Installation

When installing Vibrating Conveyors, especially MVCB and BM models, in restricted spaces such as in pits, it is necessary to allow room for servicing and maintenance requirements. The diagram shows suggested installation of an MVCB Balanced Conveyor.

- Please consult us on any concerns about vibration pollution.
- When installing on an elevated base or at high level, allowance must be made for dynamic load.
- Recommended thickness of concrete  
Up to MVCB-1050: at least 200mm  
Over MVCB-1200: at least 250mm

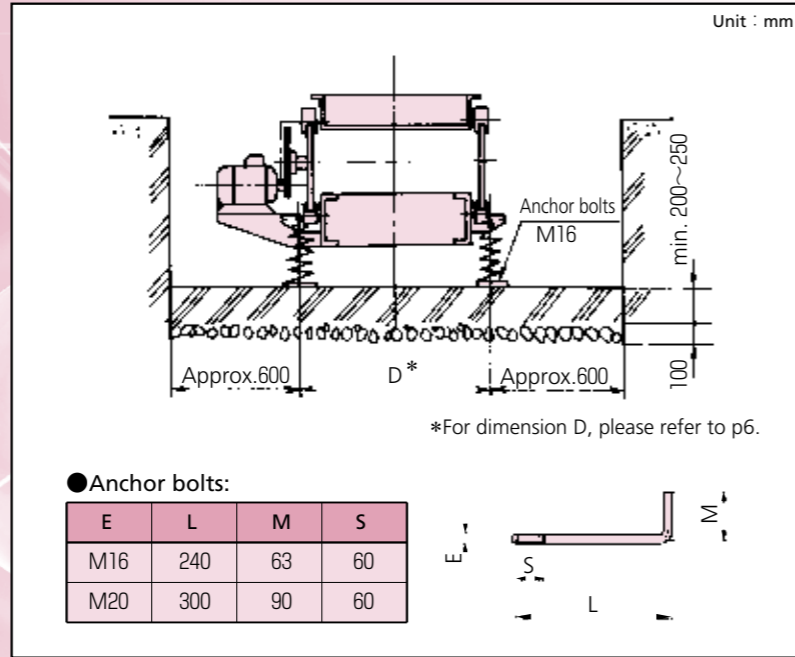

# Suspending devices

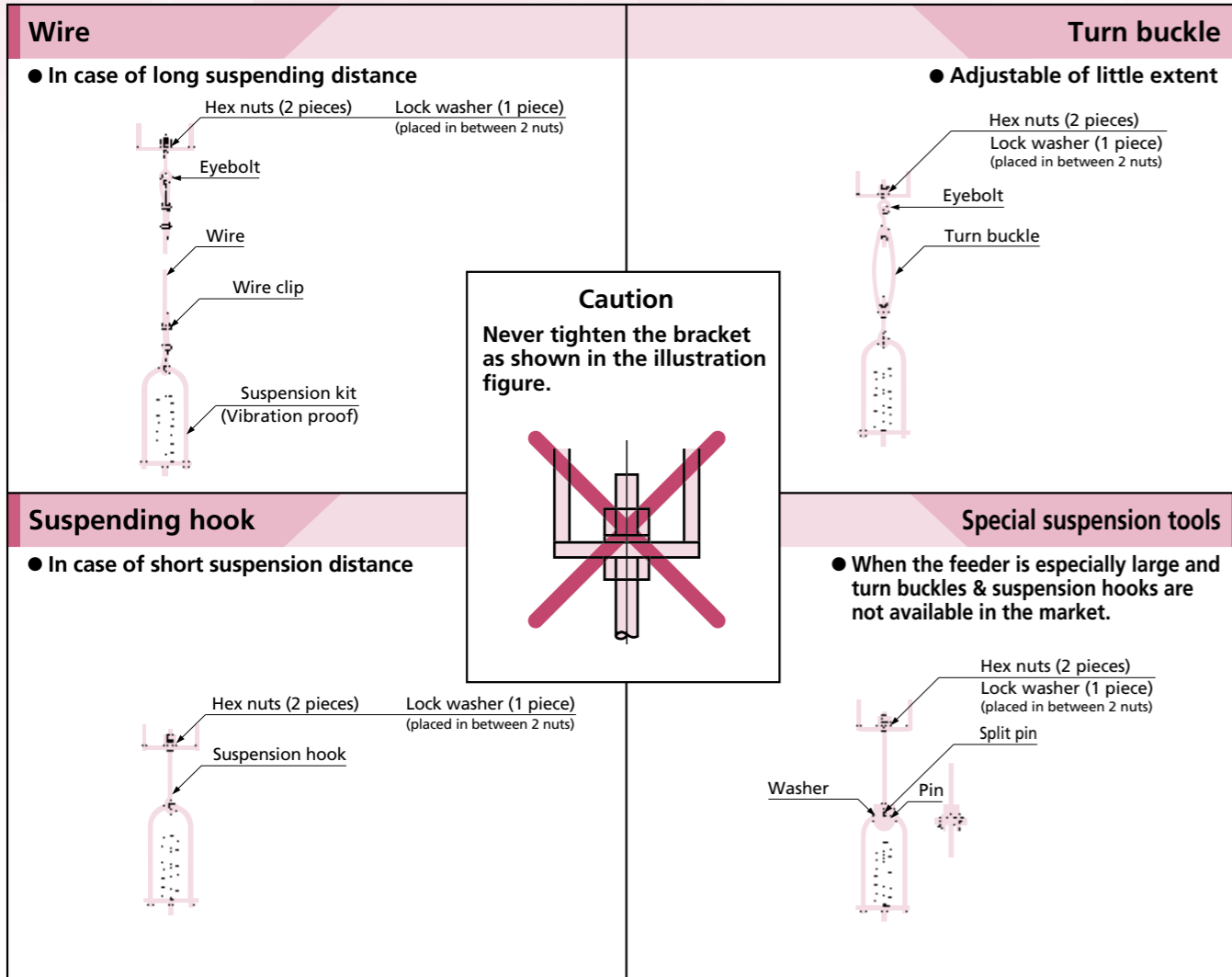

# Troughs

In general, troughs are made of standard steel plate. To meet special conveyance needs, stainless steel troughs, linings of rubber or wear-resistant steel, or troughs coated with Teflon etc. can be supplied. Alternatively, the trough surface can be buffed for use with foodstuffs, drugs and other materials requiring conveyance under hygienic conditions. All conveyor models have an open flat-based trough supplied as standard, but the following troughs are available for special requirements.

